



DBI-SALA®  
ADVANCED PRODUCTS

Now part of



capital  
SAFETY

a 3M company

# CONFINED SPACE ENTRY & RETRIEVAL



THE ULTIMATE IN FALL PROTECTION



# LEADERS IN CONFINED SPACE ENTRY AND RETRIEVAL FALL PROTECTION

## INDUSTRY EXPERIENCE

Confined spaces can be below or above ground and are found on most job sites. Each year many workers are injured or killed while performing their daily work activities in confined spaces. Confined spaces have limited openings for entry and exit which complicates rescue/retrieval and other emergency response services. These often dangerous work environments are enclosed or partially enclosed and not designed or intended for long-term human occupancy. A restrictive confined space can represent health and safety risks to anyone who enters.

Capital Safety is the only global company that has been dedicated entirely to fall protection and confined space entry/retrieval and rescue.

Our ISO 9001-2000 certification drives superior engineering, quality manufacturing and unparalleled customer services. Our design and engineering teams excel at finding the best way to keep workers totally safe and comfortable.

Combining experience and knowledge with state-of-the-art outdoor and indoor testing procedures, we produce the most technologically advanced safety equipment in the world. This equipment exceeds both national and international standards, including OSHA, ANSI, CSA, CE and AS/NZS. We call it "creating a higher standard of safety."

## YOUR PARTNER IN SAFETY

The highly trained professionals at Capital Safety educate, train and provide extensive long term support to ensure that all aspects of your fall protection program are successful.

Choose DBI-SALA® brand products - your one-stop for the most comprehensive collection of innovative fall protection products for any confined space application!

## CE EN795 CLASS B TRANSPORTABLE ANCHORAGE POINT

All Capital Safety's systems and anchor products fully meet or exceed every key safety standard required including Directive 89/696/EEC and European Standards EN795. Our products are independently tested and certified, CE marked where allowed, and are fully supported by EC Declarations of Conformity.



## CONTENTS

INDUSTRY EXPERIENCE	2	TRIPODS	17
ABC'S OF FALL PROTECTION	3	SIDE ENTRY SYSTEM	19
HOIST SYSTEMS	4-13	PORTABLE FALL ARREST SYSTEM	20
COUNTERWEIGHT SYSTEMS	13-14	DIGITAL WINCHES & ACCESSORIES	23-25
DAVIT ARM BAGS & ACCESSORIES	15	CONFIDENCE AT HEIGHT	26
POLE HOIST SYSTEMS & ACCESSORIES	16	HOW TO CONTACT US	27

## THE ABCs OF FALL PROTECTION

DBI-SALA® & Protecta® offers a complete array of passive and active fall arrest systems. The basics of every personal fall arrest system can be described as the ABC's of fall arrest.

### A - ANCHORAGE

Anchorage means a secure point of attachment (structure) for the fall arrest system. The type of anchorage varies with the application, the job being performed, the type of installation and the structure available. The anchorage connector provides a means of attaching the system to the anchorage (structure).

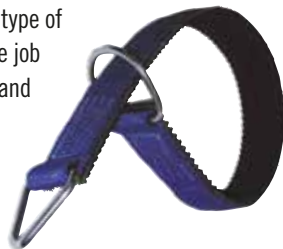

### C - CONNECTORS

Connectors are devices used to connect the worker's full body harness to the anchorage system. Connectors include lanyards, snap hooks, carabiners, deceleration devices and specialty systems such as self retracting lifelines, ladder climbing systems, vertical lifelines and rope grabs.



### B - BODY SUPPORT

Full body harnesses provide a connection point on the worker for the personal fall arrest system. Depending on the application, they can be used as part of a system to protect the worker from falling and to limit the extent of potential injury in case of a fall.



### D - DESCENT/RESCUE

Rescue and retrieval of a fallen worker is a required component of any Fall Protection Program.



## ADVANCED HOIST SYSTEMS

The Advanced Series Hoist Systems are designed for manhole and confined space entry/retrieval applications.

These units are constructed of lightweight materials including high-strength aluminum. The Davit pivots for ease of rescue and has a limited adjustment for overhead clearance restrictions.

The lower base adjusts to fit most standard entries. Many other bases are available. Check specific instruction for use of each product configuration and operation limits



### ADVANCED 5-PIECE HOIST SYSTEM

Model	Description	Weight
8568000	Includes Small offset adjustable upper mast (8568001), 33" (838mm) lightweight lower mast (8568002), and 3-piece lightweight base (8568005). 5-piece hoist system must not be modified. Note: Winch not included	100 lbs (45.5 kg)

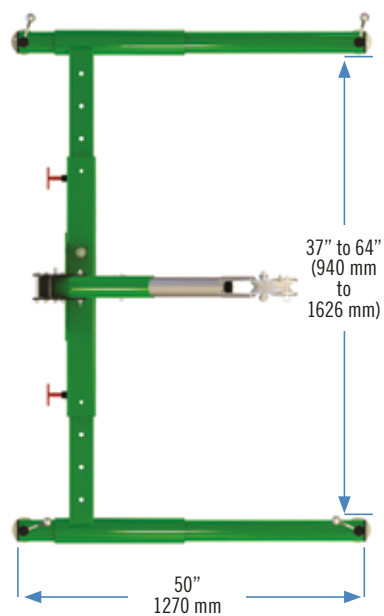
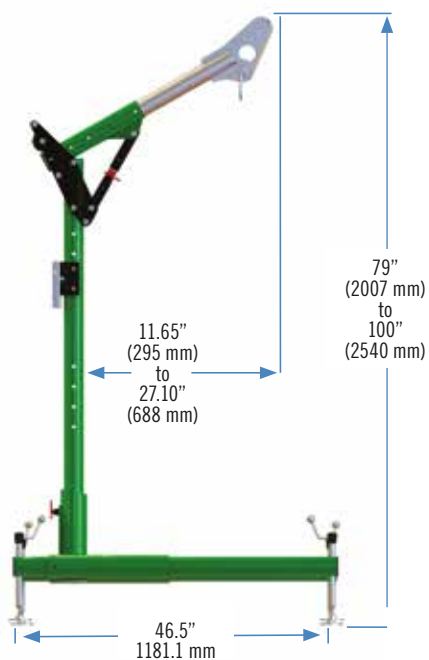



### ADVANCED 5-PIECE HOIST SYSTEM

Model	Description	Weight
8568040	Includes Large offset adjustable upper mast (8568006), 33" (838mm) lightweight lower mast (8568002), and 3-piece lightweight base (8568008). Includes winch mount brackets.	137.5 lbs (62.3 kg)

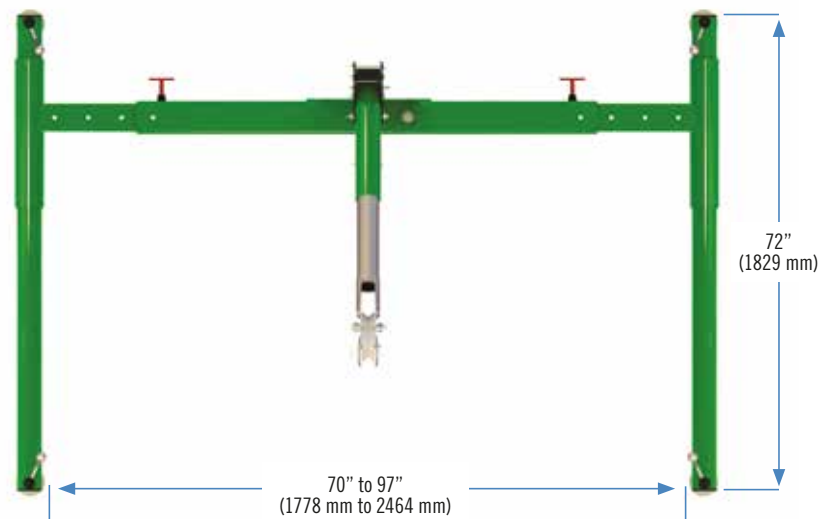
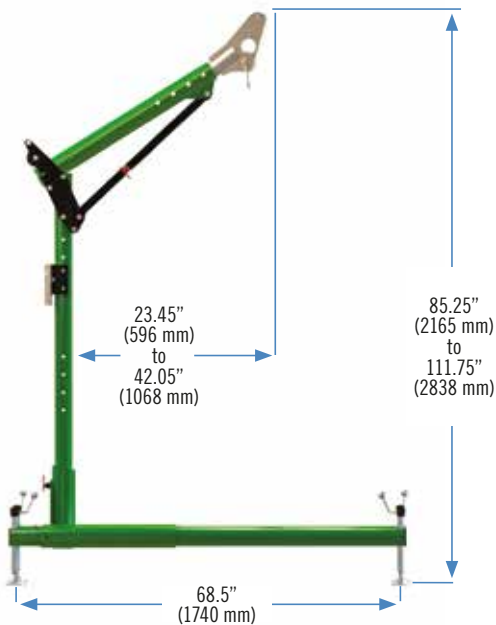

## ADVANCED DAVIT ARM SYSTEM & COMPONENTS

Variable Offset Davits are designed for use where multiple offset masts are required.

The Variable Offset Masts may be equipped with front mounted and/or back mounted winches or SRL's and feature an EN795 class B CE anchor point for fall-arrest anchorage. For applications with overhead clearance restrictions, the adjustable height of the Variable Offset Masts can eliminate the need for custom length masts and mast extensions.

The addition of the quick-release pin allows for easy collapsibility and transport.

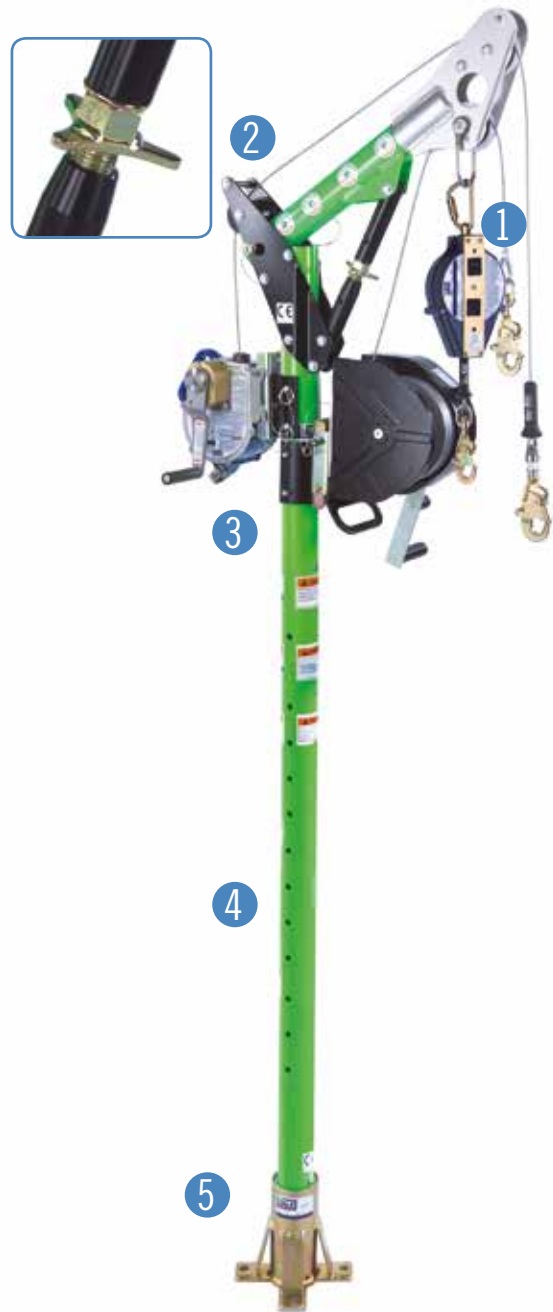

## ADVANCED DAVIT ARM SYSTEMS

### 1. Fall Arrest Anchorage

Davits feature an EN795 class B CE anchor point for fall arrest anchorage.

### 2. Adjustable Height

Eliminates the need for custom length masts and extensions.

### 3. Winch Options

Davits can be equipped with back mounted winches or SRL's with retrieval capabilities.

### 4. Lower Mast Extensions

Allow the user to increase the overall anchorage height of the system granted that the limitations of use of the IFU are followed.

### 5. Base Options

Several portable and fixed base options are available for complete versatility.

# ADVANCED ADJUSTABLE OFFSET DAVITS/UPPER & LOWER MASTS & EXTENSIONS

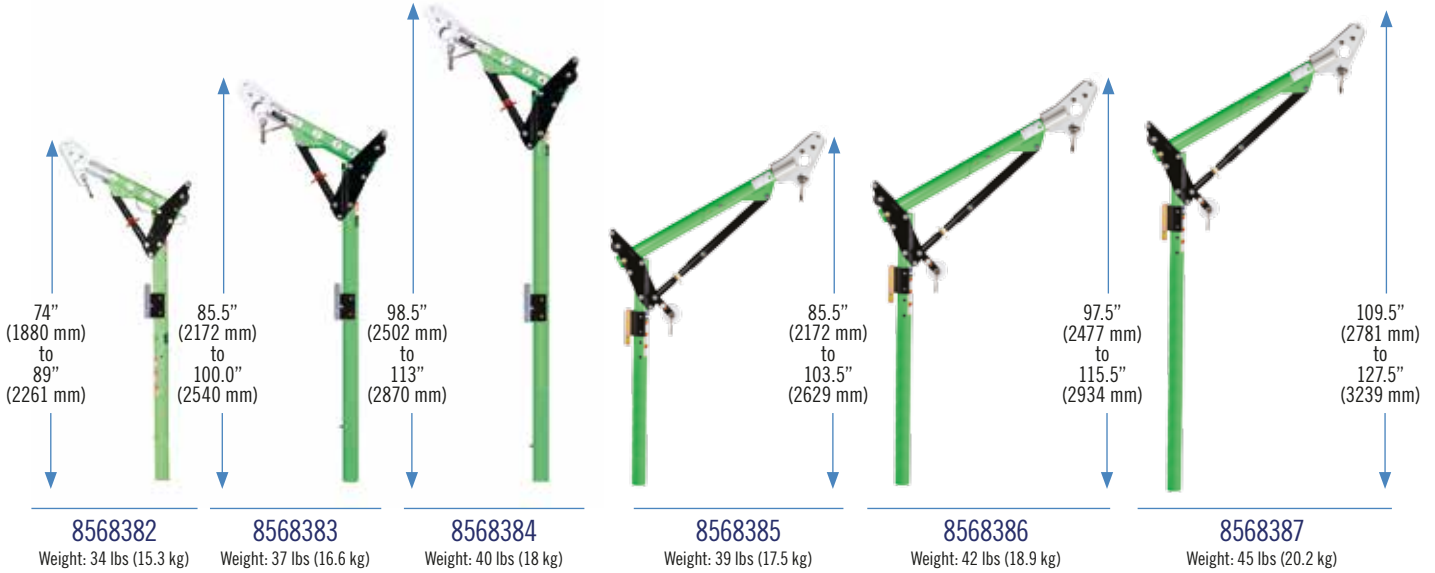

## SMALL OFFSET ADJUSTABLE MAST

## LARGE OFFSET ADJUSTABLE MAST

Lower mast extension must not be used with one piece davit. See each device for specific maximum extension length.

## ADVANCED ONE PIECE ADJUSTABLE OFFSET DAVITS

Model	Description
8568382	Small Offset Adjustable Mast, 11.65" (295 mm) to 27.10" (688mm), Anchor Point Height 66" - 76" (1676 mm - 1930.3 mm).
8568383	Small Offset Adjustable Mast, 11.65" (295 mm) to 27.10" (688mm), Anchor Point Height 78" - 88" (1981.1 mm - 2235.2 mm).
8568384	Small Offset Adjustable Mast, 11.65" (295 mm) to 27.10" (688mm), Anchor Point Height 90" - 100" (2286 mm - 2540 mm).
8568385	Large Offset Adjustable Mast, 23.45" (596 mm) to 42.05" (1068mm), Anchor Point Height 69.5" - 87.5" (1765.3 mm - 2222.5 mm).
8568386	Large Offset Adjustable Mast, 23.45" (596 mm) to 42.05" (1068mm), Anchor Point Height 81.5" - 99.5" (2070.1 mm - 2527.2 mm).
8568387	Large Offset Adjustable Mast, 23.45" (596 mm) to 42.05" (1068mm), Anchor Point Height 93.5" - 111.5" (2374.9 mm - 2832.1 mm).

## ADVANCED UPPER MASTS

Masts come standard with one set of winch mount brackets to accommodate a DBI-SALA® winch or SRL. Additional brackets are available.

## ADVANCED LOWER MASTS

Working length lower mast/extensions for use only with Advanced Series Davit, meeting limitation of use of upper masts.

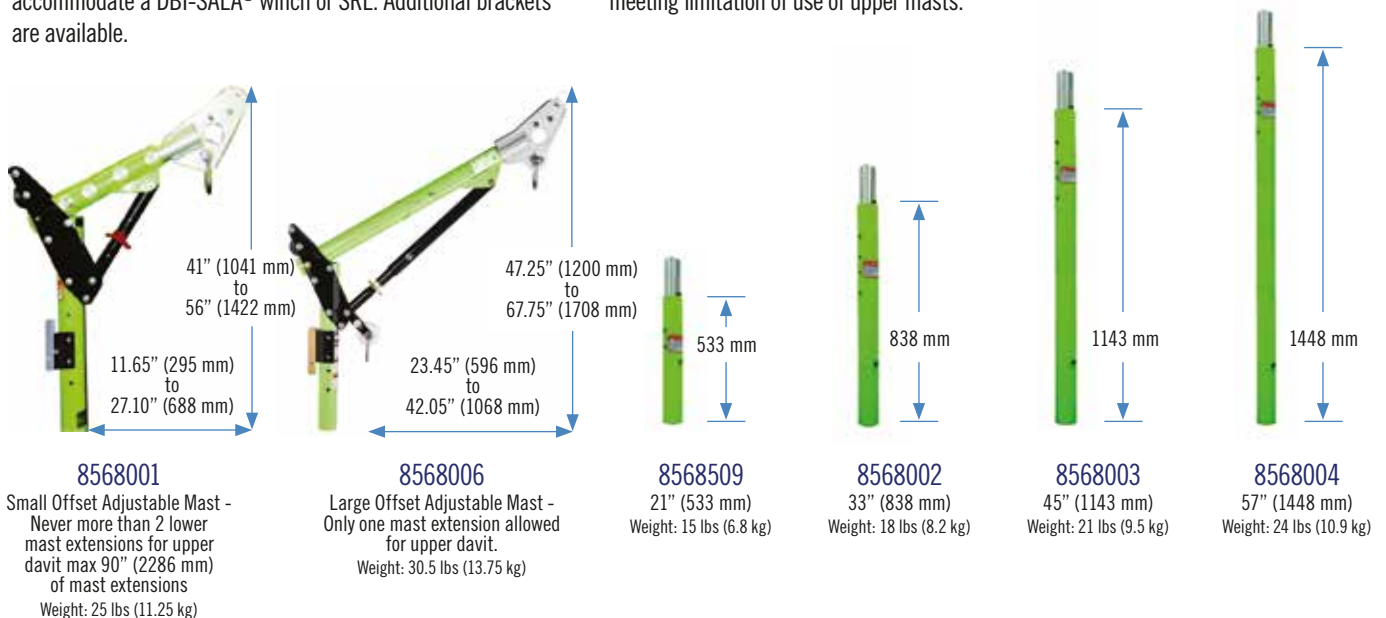

## ADVANCED PORTABLE BASES

### Advanced Portable and Fixed Bases work with a variety of Advanced Davit Arm and Mast Extensions.

Portable bases are ideal for work areas where frequent set-up and tear down is required.

Fixed bases mount to existing structures.



#### BARREL MOUNT SLEEVE WITH 3.5" (89 MM) OPENING

Model	Description	Weight
8560323	Mild steel construction. Eight independent clamping screws allow temporary installations over edges of shoring cans, walls and other structures. Comes with PVC inner liner. Can only be used with a small offset davit.	36.5 lbs (16.6 kg)

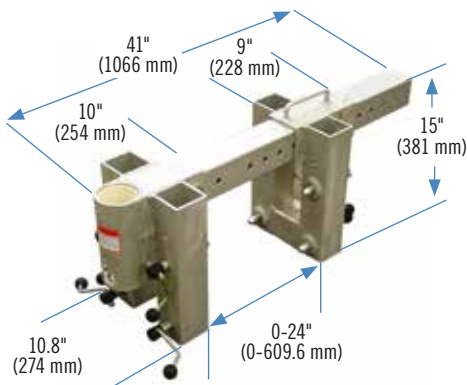

#### ADJUSTABLE BARREL MOUNT SLEEVE

Model	Description	Weight
8562285	Designed for shoring, wall and parapet applications where frequent set-up over varying wall thicknesses is required. Standard unit accommodates wall thicknesses up to a maximum of 24" (609.6 mm), with shorter or longer adjustment tubes available on request. Anodized, welded aluminum with zinc plated steel hardware for lightweight durability. Comes with inner sleeve. Can only be used with a small offset davit.	56 lbs (25.5 kg)





## ADVANCED VEHICLE HITCH MOUNT SLEEVE

The Vehicle Hitch Mount Sleeve is designed to install into a 2" (51mm) hitch receiver on an attendant vehicle to provide a portable anchor point for confined space entry/retrieval, rescue and fall-arrest systems.

Various sockets, extensions and accessories are available to allow use of the sleeve in a multitude of situations.

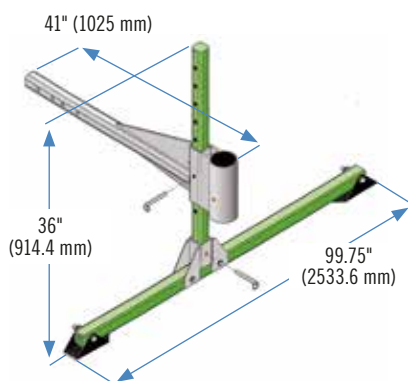
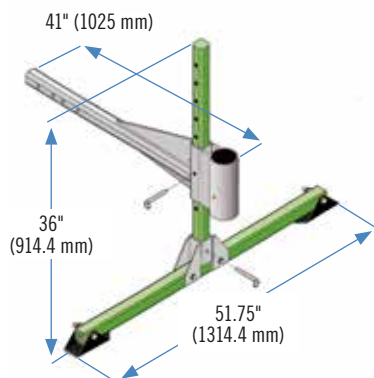

### VEHICLE HITCH MOUNT SLEEVE

Model	Description	Weight
8560140	Assembly for a Small Offset Davit	57 lbs (25.8 kg)

### VEHICLE HITCH MOUNT SLEEVE

Model	Description	Weight
8564461	Assembly for a Small or Large Offset Davit	62 lbs (28.1 kg)

Extensions are available in a variety of lengths. A maximum of one extension can be used with a hitch mount and a bumper attachment.



### VEHICLE HITCH SLEEVE EXTENSIONS

Model	Description	Weight
8514503	2' (0.61 m) Sleeve Extension	17 lbs (7.7 kg)
8512829	4' (1.21 m) Sleeve Extension	27.8 lbs (12.6 kg)
8511384	6' (1.83 m) Sleeve Extension	39 lbs (17.6 kg)

### BUMPER ATTACHMENT OPTIONS

Model	Description	Weight
8511401	<b>Universal Joint Assembly</b> - The Universal Joint Assembly installs between the standard model 8560140 Hitch Mount Sleeve or extensions and the attendant's vehicle to compensate for uneven ground conditions at the site.	10 lbs (4.5 kg)
8520886	<b>Universal Hitch Ball Coupler</b>	16 lbs (7.6 kg)



## ADVANCED FIXED BASES

Advanced Portable and Fixed Bases work with a variety of Advanced Davit Arm and Mast Extensions.

Portable bases are ideal for work areas where frequent set-up and tear down is required. Fixed bases mount to existing structures.

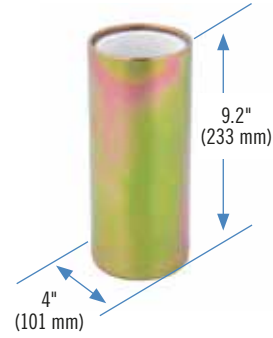
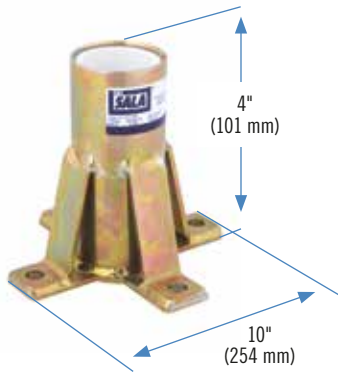

### FLOOR MOUNT SLEEVE

Model	Description	Weight
8566190	Zinc-plated mild steel construction. Mounts to horizontal concrete or steel structure. Comes with PVC sleeve liner.	13 lbs (5.9 kg)
8568347	304 Stainless Steel	13 lbs (5.9 kg)

### CORE MOUNT SLEEVE

Model	Description	Weight
8560109	Zinc-plated mild steel construction. Designed for slip-in installation into 4"ø (101.6 mm) core hole in concrete or in an existing steel structure. Comes with PVC sleeve liner.	8 lbs (3.6 kg)
8560110	Stainless Steel	8 lbs (3.6 kg)



# DBI-SALA® ADVANCED PRODUCTS

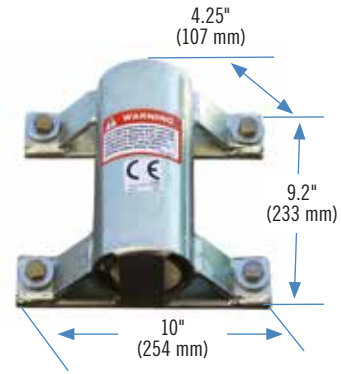

## FLUSH FLOOR MOUNT SLEEVE

Model	Description	Weight
8560316	Mild Steel construction. Recessed fastener pockets allow for bolt-in installation into existing concrete structure. Flush mount design allows passage of traffic and eliminates trip hazards when not in use. Comes with PVC sleeve liner.	21 lbs (9.5 kg)
8562827	Stainless steel construction for existing concrete installation.	21 lbs (9.5 kg)

## WALL MOUNT SLEEVE

Model	Description	Weight
8568348	304 Stainless Steel construction. Compact design creates minimum intrusion into work space. Mounts to vertical concrete or steel structures. Comes with PVC sleeve liner.	12 lbs (5.5 kg)
8566191	Zinc-plated mild steel construction.	12 lbs (5.5 kg)

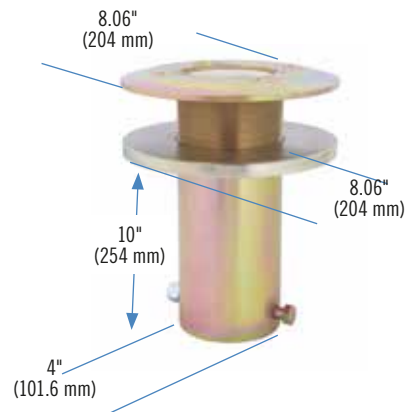
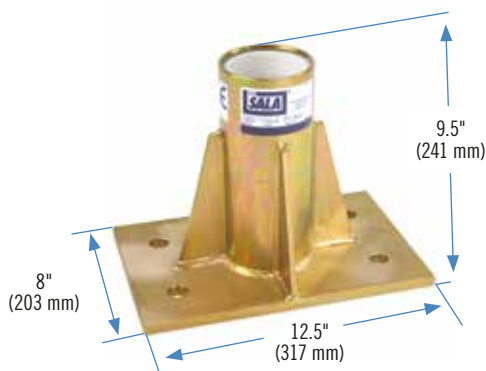

## CENTER MOUNT SLEEVE

Model	Description	Weight
8562831	Zinc Plated Mild Steel construction. Mounts to existing concrete. Comes with PVC sleeve liner.	13 lbs (5.9 kg)
8566563	Stainless Steel	13 lbs (5.9 kg)

## DECK MOUNT SLEEVE

Model	Description	Weight
8565162	Designed to slip into a 4" (101.6 mm) hole in existing flooring. Flush mount design allows passage of traffic and eliminates trip hazards when not in use. Comes with all necessary hardware. Mounts to thicknesses from 1/4" (6.4 mm) to 2.0" (50.8 mm) max.	17 lbs (7.7 kg)
8565834	Stainless Steel	17 lbs (7.7 kg)



## SLEEVE CAPS

Model	Description	Weight
8510827	High strength, stainless steel model	0.89 lbs (0.403 kg)
8510826	High strength, galvanized steel model	1.16 lbs (0.526 kg)

## ADVANCED COUNTERWEIGHT SYSTEMS

The Advanced Counterweight System is composed of a central base unit to accommodate a variety of anchoring options, positioning and adjustment legs, and extension assemblies.

Anchoring options include a weight rack for counter balanced applications, and a wheel pad assembly to allow counter balance of the unit with an attendant vehicle.

NOTE: Individual weight plates sold separately.

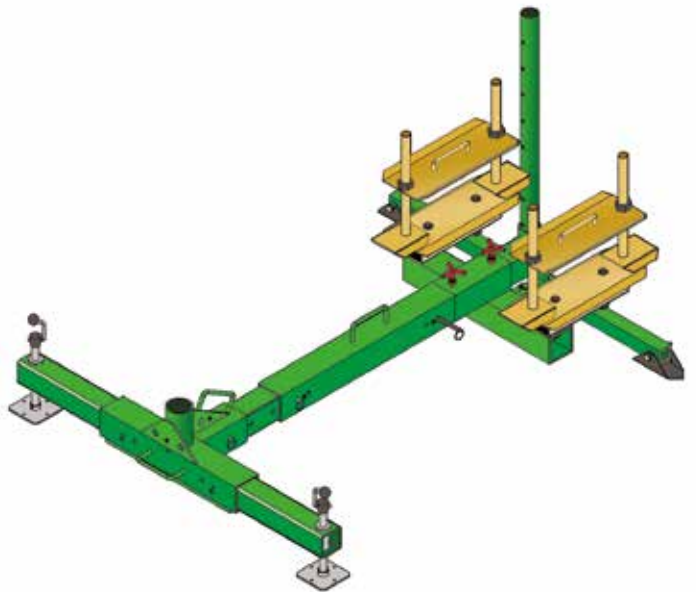

### COUNTERWEIGHT SYSTEM BASE

Model	Description	Weight
8562894	w/Pole Leg Assembly.	199 lbs (90.2 kg)

Note: Winch and davit not included.

\*Can only be used with a small offset davit.

### COUNTERWEIGHT SYSTEM BASE

Model	Description	Weight
8564496	w/Screw Leg Assembly Use this base assembly with the Advanced Catwalk Clamp to secure to the underside of elevated walkways, catwalks and mezzanines. This option offers a flexible means of tank entry into challenging areas. Weight plates sold separately.	192 lbs (87.1 kg)

\*Can only be used with a small offset davit.

## ADVANCED COUNTERWEIGHT SYSTEMS

The Counterweight Base assembles and disassembles without tools and can be fitted with a variety of anchorage and davit arm options for complete versatility.

The Pole Leg Assembly system is ideal for use with the Counterweight Rack and Vehicle Counterweight Wheel Pad to adjust the height of the system to accommodate a leading edge.

The Screw Leg Assembly System is ideal for use with the Counterweight Cart and Catwalk Clamp.

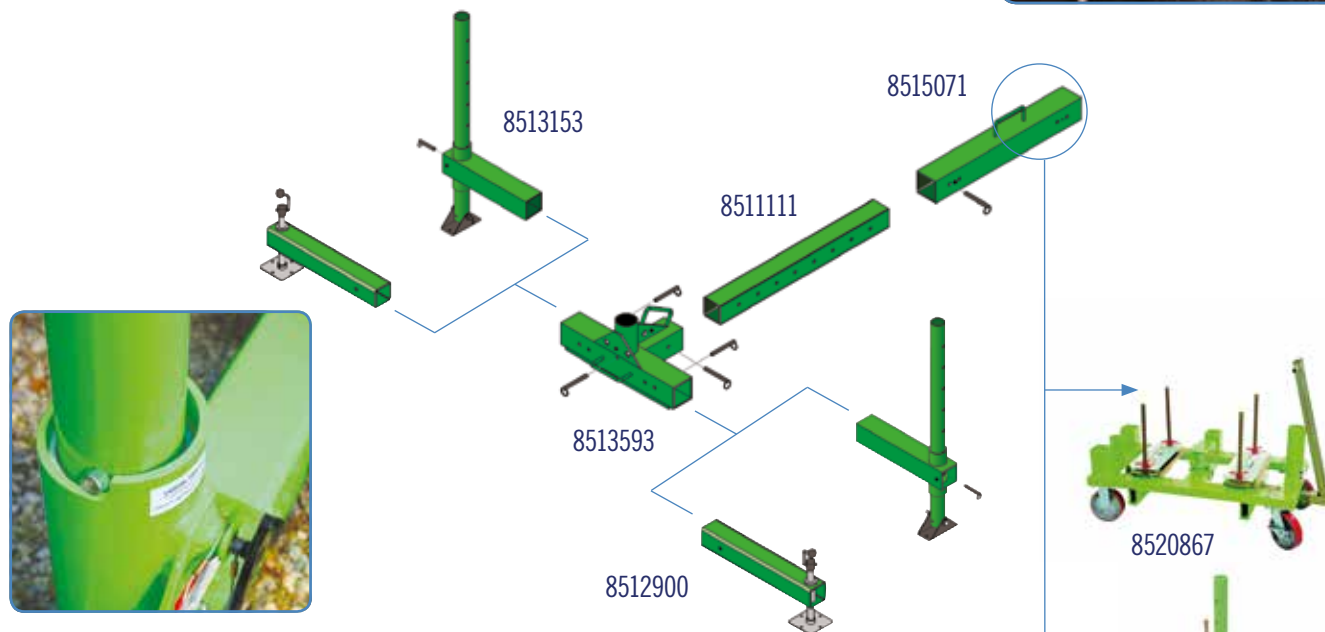

Model	Description	Weight
8513593	<b>Center Section Base</b> For Counterweight System	22 lbs (9.9 kg)
8511111	<b>36" (914 mm) Inner Extension Tube</b> For the Counterweight Base	10 lbs (4.5 kg)
8515071	<b>31" (787 mm) Outer Extension Tube</b> For the Counterweight Base	12 lbs (5.4 kg)
8513153	<b>Adjustable Height Pole Leg Section</b> To accommodate maximum 29" (736 mm) offset. Requires two. *Can only be used with a small offset davit.	6 lbs (2.7 kg)
8514418	<b>Adjustable Height Pole Leg Section</b> To accommodate maximum 48" (1219 mm) offset. Requires two. *Can be used with a Small or Large offset davit.	8 lbs (3.6 kg)
8512900	<b>Leg Section with Screw Legs</b> To accommodate maximum 0" - 29" (736 mm) offset. Requires two. *Can only be used with a small offset davit.	12 lbs (5.4 kg)
8520887	<b>Leg Section with Screw Legs</b> To accommodate maximum 30" - 48" (762 mm - 1219 mm) offset. Requires two. *Can be used with a Small or Large offset davit.	14 lbs (6.3 kg)
8520867	<b>Counterweight Cart</b> Offers a portable solution to move your counterweight easily & effectively in areas throughout a plant on level ground. Weight plates sold separately. Use with Pole Leg assemblies 8513153 & 8514418.	300 lbs (136 kg)
8513515	<b>Counterweight Rack Assembly</b> Accommodates a maximum of twenty-nine 50 lb (22.5 kg) weight-lifting plates for 1450 lbs (6.35 kg) of anchorage. Weight plates sold separately.	88 lbs (9.9 kg)
8520866	<b>Catwalk Clamp</b> Designed to secure to the underside of elevated walkways, catwalks & mezzanines. This option offers a flexible means of tank entry into challenging areas. The 8515071 Outer Tube is not required when using the catwalk clamp. Custom inner tube lengths available for different width walkways. Please call.	26 lbs (11.8 kg)
8513618	<b>Vehicle Counterweight System Wheel Pad</b> Allows counter balance of the Counterweight System with an attendant vehicle.	40 lbs (18.4 kg)

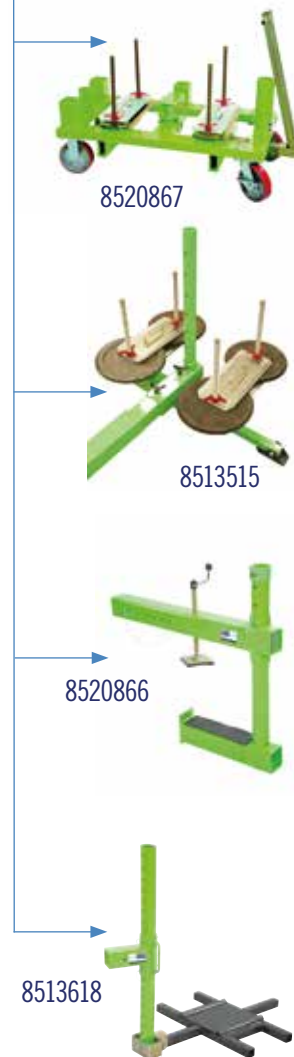

## DAVIT ARM BAGS & ACCESSORIES

These essential accessories make transportation and storage of your Advanced Hoist Systems and components simple and easy.



8513330



8513565



### ADVANCED 5 PIECE EQUIPMENT CART

Model	Description	Weight
8518270	Transport the Advanced Five Piece System with maximum ease over smooth or rough terrain. Ideal for tight storage situations.	40 lbs (8.9 kg)

### CARRYING BAGS

Model	Description
8513330	<b>Carrying Bag</b> with protective plastic liner for Advanced Davit arms (8568383, 8568384, 8568386 and 8568387).
8513564	<b>Carrying Bags</b> for 8568001 upper mast and 8568002 lower mast w/protective plastic liner.
8518513	<b>Set of 2 Carrying Bags</b> for Model 8568000 5 Piece Hoist systems.
8513565	<b>Carrying Bags</b> for 3 Piece Base c/w protective plastic liner. (8568005)
8513329	<b>Carrying Bag</b> for Davit (8568382, 8568385)



## POLE HOIST SYSTEMS & ACCESSORIES

The Advanced Pole Hoist attaches with a carabiner on the universal bracket to a suitable anchor point, allowing you to work in any direction from any angle. The Advanced Pole Hoist has a unique swivel head that rotates 360 degrees, providing unparalleled flexibility in both vertical and horizontal confined-space entries. Overall length adjusts from either 4' - 7' (1.2 m - 2.13 m) or 6' - 10' (1.8 m - 3.05 m) for positioning attendant for working in close quarters.

Custom Pole Hoist sizes are available. Please call for more details.

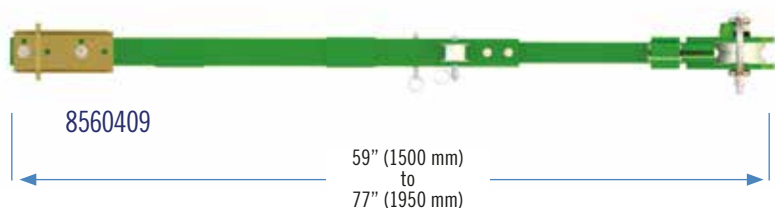

### ADVANCED 4' - 7' (1.2M - 2.13M) EXTENDABLE POLE HOIST

Model	Description	Weight
8560409	4'-7' (1.2 m - 2.13 m) Extendable Pole Hoist, swivel head & stainless steel hardware. Includes winch bracket.	12 lbs (5.4 kg)

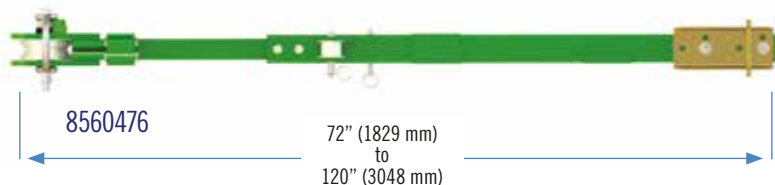

### ADVANCED 6' - 10' (1.8 M - 3.05 M) EXTENDABLE POLE HOIST

Model	Description	Weight
8560476	6'-10' (1.8 m - 3.05 m) Extendable Pole Hoist, swivel head & stainless steel hardware. Includes winch bracket.	14 lbs (6.4 kg)

### ACCESSORY OPTIONS

Model	Description
8561235	T-bar leg assembly with stainless steel hardware (required)
8513329	Carrying Bag for 4'-7' (1.2 m - 2.13 m) Pole Hoist
8513330	Carrying Bag for 6'-10' (1.8 m - 3.05 m) Pole Hoist



## ADVANCED TRIPODS

Advanced Tripods are constructed of lightweight tubular aluminum with a rugged steel head assembly. The UCT-300 and UTC-1000 Tripods can be combined with up to three pulleys to accommodate a variety of winches and fall-arrest devices to meet a wide range of confined space entry/retrieval and rescue requirements.

Pulleys are mounted on top of the head assembly to provide extra overhead clearance in tight situations. Quick release pins positively locate components at all adjustment points for tool-less setup and adjustment.



### ADVANCED UCT-300 7' (2.13 M) TRIPOD

Model	Description	Weight
8563158	Advanced UCT-300 7 ft. (2.13 m) Tripod with adjustable locking legs, safety chains, top pulley & winch bracket. Note: Winch not included	47,6 lbs (21.6 kg)

### ADVANCED UCT-1000 10' (3.05 M) TRIPOD

Model	Description	Weight
8563159	Advanced UCT-300 10 ft. (3.048 m) Tripod with adjustable locking legs, safety chains, top pulley & winch bracket. Note: Winch not included	68 lbs (30.8 kg)

# DBI-SALA® ADVANCED PRODUCTS

## CANTILEVER RESCUE SYSTEM KIT

Model	Description	Weight
8562297	The Cantilever Rescue System Kit quickly and easily converts your UCT-1000 10 ft. (3.05 m) tripod into a versatile piece of equipment for confined space entry/retrieval and high-angle rescue operations over roof edges, parapets, guard rails, cliffs, bridges or other situations. Using the rigid wheel pad supplied with the kit, the cantilever system may be anchored with a service vehicle's weight or weight rack.	29.7 lbs (13.5 kg)

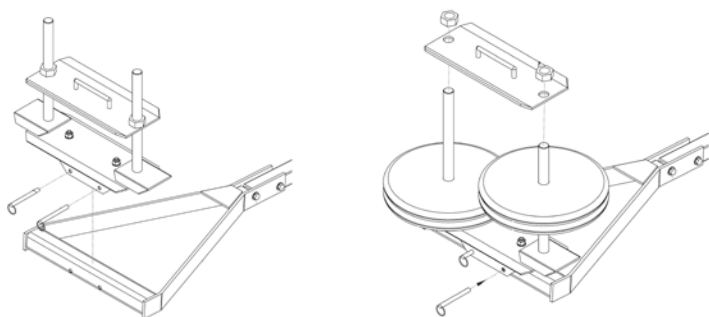

## CANTILEVER KIT WEIGHT RACK FOR USE WITH THE UCT-1000 TRIPOD

Model	Description	Weight
8515631	Use the weight rack in conjunction with the UCT-1000 tripod and cantilever system for counter balanced confined space entry/retrieval and rescue operations over roof edges, parapets, guard rails, cliffs, bridges or other situations. 50 lb. (22.7 kg) weight plates sold separately.	36 lbs (16.3 kg)

## TOP MOUNT PULLEY FOR CANTILEVER SYSTEM

Model	Description	Weight
8515150	Converts the system to handle both a winch & SRL.	3.4 lbs (1.5 kg)

## ADVANCED TRIPOD ACCESSORIES

Model	Description
8513329	Carrying bag with protective plastic liner for 7 ft. (2.13 m) tripod
8513330	Carrying bag with protective plastic liner for 10 ft. (3.05 m) tripod



## WINCH MOUNTING BRACKET FOR UCT-300 TRIPOD

Model	Description	Weight
8510224	Attaches to the leg tube with quick-release pins for toolless set-up and adjustment.	3 lbs (1.4 kg)

## WINCH MOUNTING BRACKET FOR UCT-1000 TRIPOD

Model	Description	Weight
8512292	Attaches to the leg tube with quick-release pins for toolless set-up and adjustment.	5.2 lbs (2.4 kg)

## TOP PULLEY ASSEMBLY FOR UCT TRIPODS

Model	Description	Weight
8512293	Pulleys are mounted on top of the head assembly to provide extra overhead clearance in tight situations.	1.6 lbs (0.73 kg)

## ADVANCED SIDE ENTRY SYSTEM

The Advanced Side Entry System is designed for confined space entry/retrieval and rescue operations involving horizontal entries with vertical positioning or retrieval required inside the space.

The Advanced Side Entry System may be used with the model 8541683 External Adjustable Tank Collar for adaptation to different manways.



Note: Winch not included

### ADVANCED SIDE ENTRY SYSTEM FOR PORTABLE MOUNT APPLICATIONS

Model	Description	Weight
8541683	External Adjustable Tank Collar, w/tie bar assemblies, used to fit outside of manway	52 lbs (23.5 kg)
8561233	Side Entry System Package for use with external adjustable tank collar or permanently mounted bases	69 lbs (31.3 kg)
8530260	Kit secondary winch mounting bracket. Allows you to mount your digital winch underneath, opening up the top winch mount location for a 3-way SRL.	4.6 lbs (2.09 kg)

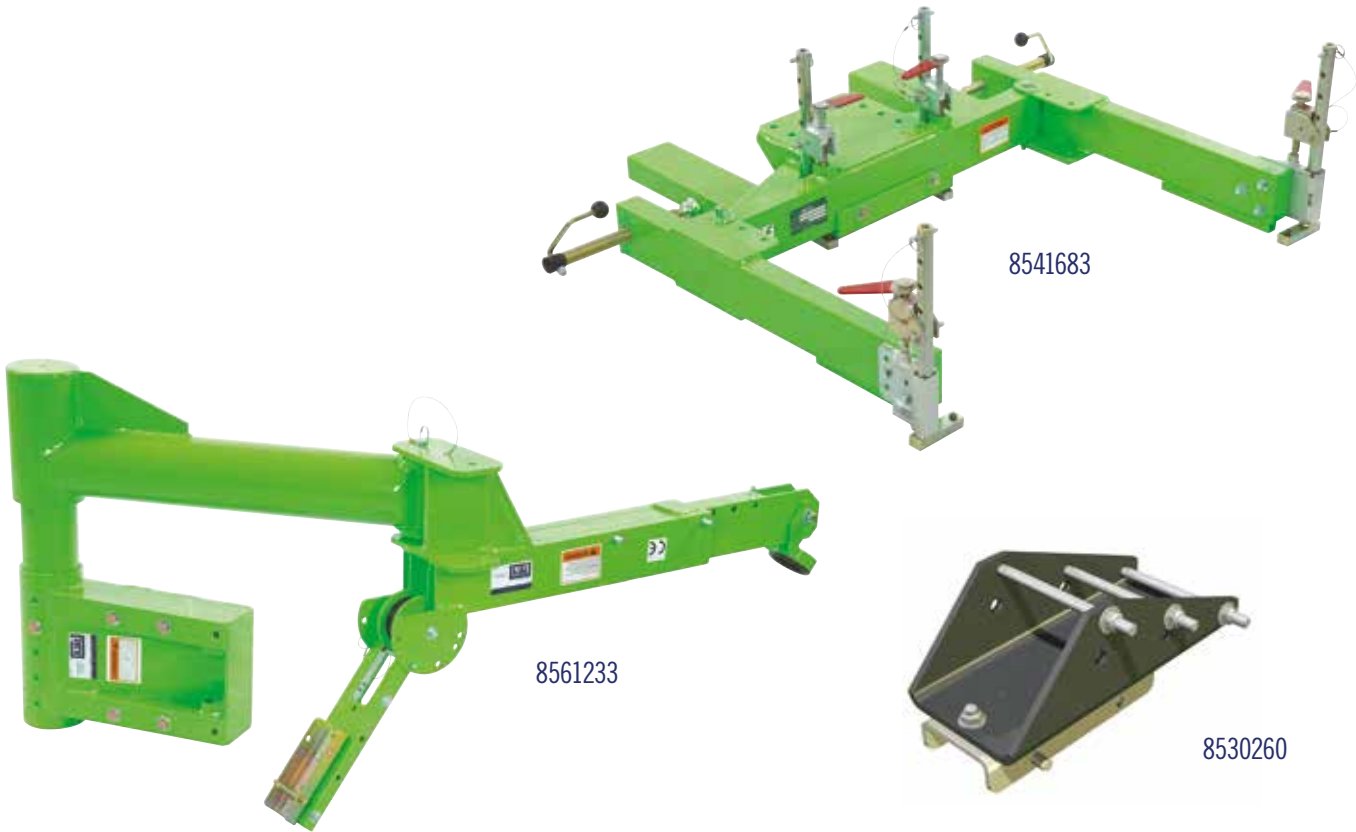

**PORTABLE FALL-ARREST SYSTEM**

The Advanced Portable Fall Arrest Post is specifically designed for use on top of transformers or other types of vertical platforms with potential fall hazards.

It's compact and lightweight design of only 38 lbs (17.2 kg) makes the post very easy to transport and put in place.

The system features 3 independent swivel anchor points. They can rotate 360 degrees, offering freedom of mobility for up to 3 workers with self-retracting lifelines or fixed length lanyards.

The Portable Fall-Arrest System has 3 telescopic working heights ranging from 30.5" (774 mm) 43" (1092 mm), all the way up to 54.5" (1384 mm). This decreases a worker's fall distance and increase the overall work area. \*NOTE: The Rescue Davit Arm works in the 2nd and 4th positions only.

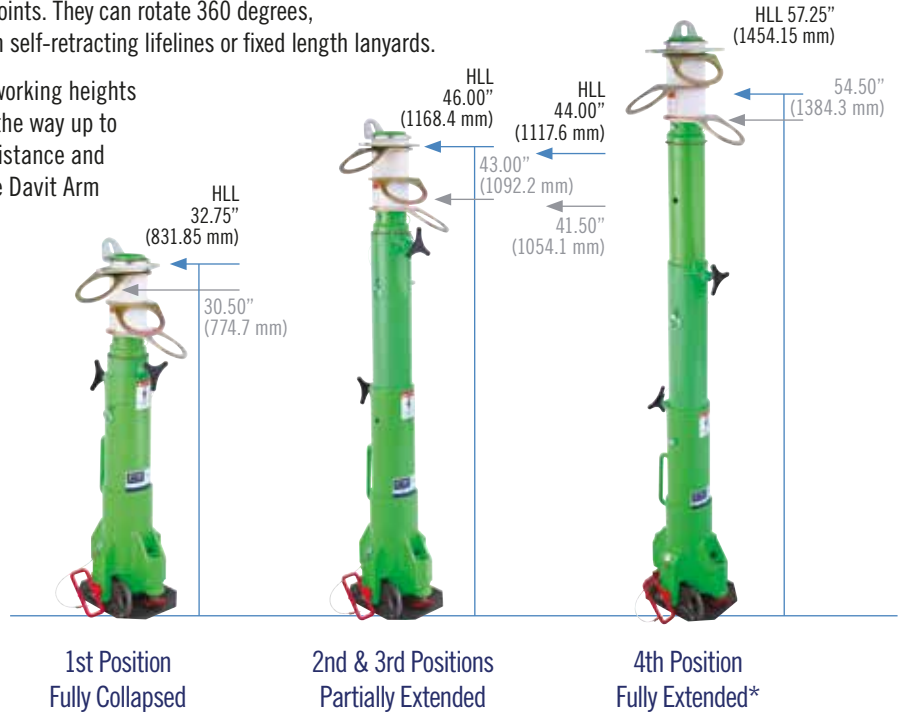

The optional Rescue Davit Arm assembles easily to address rescue needs. It's made with lightweight aluminum materials for easy transportation and setup. \*NOTE: The Rescue Davit Arm works in the 2nd and 4th positions only. See previous page.

**ADVANCED PORTABLE FALL ARREST POST**

Model	Description	Weight
8566691	Advanced Portable Fall Arrest System	38 lbs (17.2 kg)
8566693	Advanced Portable Fall Arrest Post Rescue Davit Arm	20.5 lbs (9.3 kg)
8517565	Heavy-duty carrying bag for davit arm only	1.5 lbs (0.68 kg)



**14" (356 MM) ANCHOR POST EXTENSION**

Model	Description	Weight
8566692	Allows for tie-off of one worker at an increased height of 68.5" (1740 mm)	5 lbs (2.2 kg)



**BARE STEEL UNI-ANCHOR WITH TIE-OFF ANCHORS**

Model	Description	Weight
8567412	For use in closed environments without chemical or moisture exposure.	11.6 lbs (5.3 kg)
8569819	Bolt down	24.25 lbs (11 kg)
8567422	Sandblasted	13.69 lbs (6.21 kg)



**UNI-ANCHOR I-BEAM BASE**

Model	Description	Weight
8566997	For connecting the PFAS to an I-Beam.	56 lbs (25.5 kg)

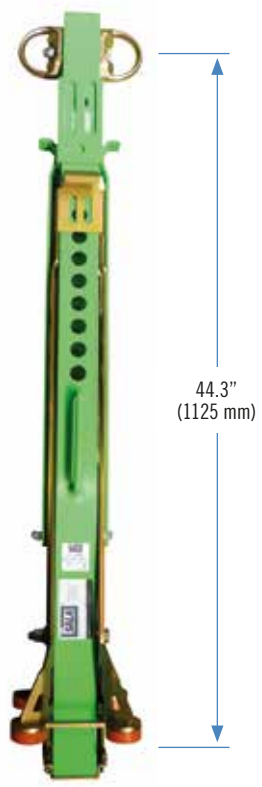

**ISO CONTAINER FALL ARREST POST**

Model	Description	Weight
8563161	Compatible with all ISO certified containers. Provides an elevated anchorage point reducing fall clearance requirements. Ensures total fall protection solution, even while working on a single container. No tools or container modification required.	26.4 lbs (12 kg)

## ADVANCED DIGITAL SERIES WINCH

Advanced Digital Series Winches are rated for a maximum working load of 450 lbs (204 kg) with an 11:1 safety factor. This winch has two cranking speeds capable of retrieval/descent from 13 ft/min (4 m/min) to 30 ft/min (9 m/min).

Advanced Digital Winches are available in 3 standard sizes. It accommodates various diameters of cables up to 3/8" (9.5 mm) and ropes up to 5/8" (15.9 mm). All cable/rope assemblies come with a double locking swivel snap hook with overload indicator.

## MAN RATED

For raising, lowering or supporting personnel. Working load 450 lbs (204 kg). Designed specifically for confined space entry/retrieval.

## DIGITAL USAGE INDICATOR

The exclusive "digital usage indicator" system counts the revolutions of the drum to determine service intervals. Additional standard features include a braking system with 3 independent working pawls, centrifugal back-up brake, carrying handle and cable retainer spring.



## COMPLIANT HARDWARE

Double locking swivel safety snaps standard on all cables. Sealed bearings at all contact points. All hardware is Zinc plated. All components are zinc-plated steel or anodized aluminum.

## TRIPLE REDUNDANT BRAKING MECHANISM

A friction brake is engaged by a minimum of 5 lbs (2 kg). Brake pad wear indicator monitors the condition of the braking mechanism, which features an inertial (centrifugal) safety back up brake.





### ADVANCED DIGITAL 100 SERIES 2 SPEED WINCH W/ REMOVABLE HANDLE

This Advanced Digital 100 Series Winch includes a removable aluminum crank handle to utilize both our 9:1 and 4:1 drives. These two drives offer the capability of retrieval/descent at average speeds from 13 ft/min (4 m/min) up to 30 ft/min (9 m/min).

Model	Description	Actual Length	Working Length	Total Weight
8518560	Advanced Digital 100 Series Removable Handle, 60' Galvanized Cable Assy	70 ft (21.3 m)	60 ft (18 m)	30.5 lbs (13.8 kg)
8518558	Advanced Digital 100 Series Removable Handle, 60' S.S. Cable Assy	70 ft (21.3 m)	60 ft (18 m)	30.5 lbs (13.8 kg)
8518561	Advanced Digital 100 Series Removable Handle, 90' Galvanized Cable Assy	100 ft (30 m)	90 ft (27 m)	32.5 lbs (14.7 kg)
8518559	Advanced Digital 100 Series Removable Handle, 90' S.S. Cable Assy	100 ft (30 m)	90 ft (27 m)	32.5 lbs (14.7 kg)

### ADVANCED DIGITAL 100 SERIES 2 SPEED WINCH W/ 9:1 POWER DRIVE & 4:1 REMOVABLE HANDLE

The Advanced Power Drive Digital Winch features a power drive hub on the 9:1 drive. An overload protection clutch installs between this power drive hub and an electric or pneumatic drill to eliminate overloading the winch during retrieval. This clutch also protects the winch operator and the retrieved worker from injury. The clutch is installed and removed without the use of tools when switching to the 4:1 manual crank option in emergencies. (8512936: Overload Protection Clutch sold separately.)

Model	Description	Actual Length	Working Length	Total Weight
8518567	Advanced Digital 100 Series Power Drive, 60' Galvanized Cable Assy	70 ft (21.3 m)	60 ft (18 m)	30.5 lbs (13.8 kg)
8518565	Advanced Digital 100 Series Power Drive, 60' S.S. Cable Assy	70 ft (21.3 m)	60 ft (18 m)	30.5 lbs (13.8 kg)
8518568	Advanced Digital 100 Series Power Drive, 90' Galvanized Cable Assy	100 ft (30 m)	90 ft (27 m)	32.5 lbs (14.7 kg)
8518566	Advanced Digital 100 Series Power Drive, 90' S.S. Cable Assy	100 ft (30 m)	90 ft (27 m)	32.5 lbs (14.7 kg)

### ADVANCED DIGITAL 200 SERIES 2 SPEED WINCH W/ REMOVABLE HANDLE

This Advanced Digital 200 Series Winch includes a removable aluminum crank handle to utilize both our 9:1 and 4:1 drives. These two drives offer the capability of retrieval/descent at average speeds from 13 ft/min (4 m/min) up to 30 ft/min (9 m/min).

Model	Description	Actual Length	Working Length	Total Weight
8518581	Advanced Digital 200 Series Removable Handle, 140' Galvanized Cable Assy	150 ft (45.7 m)	140 ft (42 m)	40 lbs (18.4 kg)
8518579	Advanced Digital 200 Series Removable Handle, 140' S.S. Cable Assy	150 ft (45.7 m)	140 ft (42 m)	40 lbs (18.4 kg)
8518582	Advanced Digital 200 Series Removable Handle, 190' Galvanized Cable Assy	200 ft (61 m)	190 ft (58 m)	43 lbs (19.5 kg)
8518580	Advanced Digital 200 Series Removable Handle, 190' S.S. Cable Assy	200 ft (61 m)	190 ft (58 m)	43 lbs (19.5 kg)

### ADVANCED DIGITAL 200 SERIES 2 SPEED WINCH W/ 9:1 POWER DRIVE & 4:1 REMOVABLE HANDLE

The Advanced Power Drive Digital Winch features a power drive hub on the 9:1 drive. An overload protection clutch installs between this power drive hub and an electric or pneumatic drill to eliminate overloading the winch during retrieval. This clutch also protects the winch operator and the retrieved worker from injury. The clutch is installed and removed without the use of tools when switching to the 4:1 manual crank option in emergencies. (8512936: Overload Protection Clutch sold separately.)

Model	Description	Actual Length	Working Length	Total Weight
8518588	Advanced Digital 200 Series Power Drive, 140' Galvanized Cable Assy	150 ft (45.7 m)	140 ft (42 m)	40 lbs (18.4 kg)
8518586	Advanced Digital 200 Series Power Drive, 140' S.S. Cable Assy	150 ft (45.7 m)	140 ft (42 m)	40 lbs (18.4 kg)
8518589	Advanced Digital 200 Series Power Drive, 190' Galvanized Cable Assy	200 ft (61 m)	190 ft (58 m)	43 lbs (19.5 kg)
8518587	Advanced Digital 200 Series Power Drive, 190' S.S. Cable Assy	200 ft (61 m)	190 ft (58 m)	43 lbs (19.5 kg)

**ADVANCED DIGITAL 300 SERIES 2 SPEED WINCH W/ REMOVABLE HANDLE**

This Advanced Digital 300 Series Winch includes a removable aluminum crank handle to utilize both our 9:1 and 4:1 drives. These two drives offer the capability of retrieval/descent at average speeds from 13 ft/min (4 m/min) up to 30 ft/min (9 m/min).

Model	Description	Actual Length	Working Length	Total Weight
8518603	Advanced Digital 300 Series Removable Handle, 240' Galvanized Cable Assy	250 ft (76.2 m)	240 ft (73 m)	50 lbs (22.6 kg)
8518601	Advanced Digital 300 Series Removable Handle, 240' S.S. Cable Assy	250 ft (76.2 m)	240 ft (73 m)	50 lbs (22.6 kg)
8518604	Advanced Digital 300 Series Removable Handle, 290' Galvanized Cable Assy	300 ft (91 m)	290 ft (88 m)	53.5 lbs (24.3 kg)
8518602	Advanced Digital 300 Series Removable Handle, 290' Galvanized Cable Assy	300 ft (91 m)	290 ft (88 m)	53.5 lbs (24.3 kg)

**ADVANCED DIGITAL 300 SERIES 2 SPEED WINCH W/ 9:1 POWER DRIVE & 4:1 REMOVABLE HANDLE**

The Advanced Power Drive Digital 300 Winch features a power drive hub on the 9:1 drive. An overload protection clutch installs between this power drive hub and an electric or pneumatic drill to eliminate overloading the winch during retrieval. This clutch also protects the winch operator and the retrieved worker from injury. The clutch is installed and removed without the use of tools when switching to the 4:1 manual crank option in emergencies. (8512936: Overload Protection Clutch sold separately.)

Model	Description	Actual Length	Working Length	Total Weight
8518610	Advanced Digital 300 Series Power Drive, 240' Galvanized Cable Assy	250 ft (76.2 m)	240 ft (73 m)	50 lbs (22.6 kg)
8518608	Advanced Digital 300 Series Power Drive, 240' S.S. Cable Assy	250 ft (76.2 m)	240 ft (73 m)	50 lbs (22.6 kg)
8518611	Advanced Digital 300 Series Power Drive, 290' Galvanized Cable Assy	300 ft (91 m)	290 ft (88 m)	53.5 lbs (24.3 kg)
8518609	Advanced Digital 300 Series Power Drive, 290' S.S. Cable Assy	300 ft (91 m)	290 ft (88 m)	53.5 lbs (24.3 kg)



**SALALIFT™ II WINCH PACKAGES**

The Salalift™ II is manually operated for easy operation. Simply rotate the handle to rescue personnel. Gear ratio is 6:1 with an average lifting speed of 12.75 ft/min (3.8 m/min). No power source is required. The Quick-Mount System incorporates a quick-mount bracket which mates with a bracket on all DBI-SALA® support structures allowing the user to attach/detach device with a detent pin to make retrofitting easy (no additional hardware needed).

Model	Description	Total Weight
KT2PW60L	Salalift™ II Winch w/ 60 ft. (18.3 m) of 1/4" (6 mm) galvanized cable, mounting bracket & winch bag	35.27 lbs (16 kg)
KT2PW120L	Salalift™ II Winch w/ 120 ft. (36.6 m) of 3/16" (5 mm) galvanized cable, mounting bracket & winch bag	38.62 lbs (17.52 kg)



## WINCH BRACKETS & ACCESSORIES



### WINCH/SRL ADAPTER WITH FLAT BACK

Model	Description
8510207	To attach DBI-SALA® winch/SRL to structures.



### QUICK RELEASE MOUNTING BRACKET

Model	Description
8516824	For Advanced Upper and Lower Masts.



### OVERLOAD PROTECTION CLUTCH

Model	Description
8512936	Features a maximum working load of 450 lbs. (204 kg). Use with cordless drill 0-300 RPM, 45 N.m torque minimum.



### PADDED CARRYING BAG

Model	Description
8517567	For Basic or Digital winch, c/w Carrying Handle.



### SEALED-BLOK™ ADAPTER

Model	Description
3401025	Attaches to Sealed-Blok™, supplied with mounting bolts, mates with 8510207, 8516480, 8516491.

# FOR ABSOLUTE CONFIDENCE AT HEIGHT, DBI-SALA® OFFERS A FULL-LINE OF FALL PROTECTION AND RESCUE GEAR

## FULL BODY HARNESSSES

- Distributes forces throughout body during a fall
- Maximum comfort, freedom of movement and ease of use
- Exhaustive designs and configurations available to suit any need



## SHOCK ABSORBING LANYARDS

- Limits fall arrest forces to under 1323 lb. (600kg)
- High strength construction
- Many configurations and hook styles available for any application



## ANCHORAGE DEVICES

- Limits fall arrest forces to under 1323 lb. (600kg)
- High strength construction
- Many configurations and hook styles available for any application



## SELF RETRACTING LIFELINES

- Extends and retracts automatically for added comfort and safety
- Limits fall arrest forces to under 1323 lb. (600kg)
- Extends safe work area, available in lengths from 8 ft. to 175 ft. (2.4 m to 53 m)



## VERTICAL LIFELINE SYSTEMS

- Mobile and static designs
- Specialized designs available for both rope and cable
- Unique braking systems stop falls quickly and safely



## HORIZONTAL LIFELINE SYSTEMS

- Precision engineered to provide horizontal movement and protection
- Wide range of styles available to suit any need
- Uniquely designed to enhance safety and productivity



## CONFINED SPACE RESCUE SYSTEMS

- Provide work support, fall protection and retrieval
- High quality, rugged systems ensure top performance when it counts
- Modular and lightweight designs for versatility and ease of use



**SALA** DELTA™ COMFORT

# DELTA™ COMFORT

**Applications**

From the biggest selling range of harnesses in the world, the revised Delta™ Comfort full-body harness offers industry-first features such as an improved ergonomic fit and feel, lighter weight buckles and high-strength webbing. Employing a patented No-Tangle™ triangle pattern creates a fit that allows the harness to easily fall into place when donned. The new Delta™ Comfort harness features liquid-resistant Repel™ webbing and Revolver™ Torso adjusters, which allow for quick adjustment and keep loose strap ends. I-Safe™ equipped.

18 WWW.CAPITALSAFETY.COM ☎ 00 800 999 55500

## DELTA™ COMFORT

FALL ARREST HARNESSES

- REPEL™ WEBBING**  
Water repellent on inside surfaces of right and left legs has up to 3 times more resistance to absorption.
- GEAR LOOPS AND CONNECTORS**  
Range of connection and storage points for tools and pouches.
- COMFORT PADDING**  
To the underside of the shoulder straps, hips and legs.
- REVOLVER™ VERTICAL TORSO ADJUSTER**  
These unique self-positioning adjusters have infinite flexibility. They are designed and built adjustment that allows you to enter and lock into place pre-positioning adjustment.
- TECH-LITE™ QUICK CONNECT BUCKLES**  
Lightweight aluminum alloy buckles for fast and easy connections. Other connectors available: Pass Through and D-ring.
- STAND UP DORSAL D-RING**  
Patented spring loading design substantially reduces self-estraining pull, easy on/off and connectors for your fall arrest system.
- RIGID BELT**  
Allows for 27" leg of tools without collapsing.
- PROTECTED LABELS WITH I-SAFE™**  
A 3M™ cover protects harness labels and makes I-Safe™ (I-Safe™) presentation the easiest way to get the most of your safety and working information at a glance.

Now part of **3M**

**capital SAFETY**  
a 3M company

# PRODUCT CATALOGUE

- A ANCHORAGES
- B BODY SUPPORT
- C CONNECTORS
- D DESCENT AND RESCUE
- E EDUCATION

GLOBAL LEADER IN FALL PROTECTION

**SALA** **PROTECTA**

## CAPITAL SAFETY PRODUCT CATALOGUE

To order a copy of the latest catalogue, call Customer Services on **00800 999 55500**.

You can also download the catalogue by visiting [www.capitalsafetymedia.eu/regionalcatalogue](http://www.capitalsafetymedia.eu/regionalcatalogue)

## HOW TO CONTACT US

For orders, enquires or Technical Support please contact our Customer Services team on the toll free number below.

☎ **00 800 999 55500** (Toll Free)

☎ **+33 (0)4 93 08 79 70**

✉ **information@capitalsafety.com**

🌐 **www.capitalsafety.com**





a 3M company

Now part of



## GLOBAL LEADER IN FALL PROTECTION

### Capital Safety is the Global leader in fall protection equipment, systems and anchors.

Capital Safety est le leader mondial en matière d'équipement, de systèmes et d'ancrages de protections antichute.

Capital Safety ist weltweit führend auf dem Gebiet von Absturzsicherungs-ausrüstung, -systemen und Anschlagmöglichkeiten.

Capital Safety es el líder mundial en equipos, sistemas y anclajes de protección contra caídas.

Capital Safety is wereldleider in valbeveiligingsapparatuur, -systemen en verankeringen.

Capital Safety è leader globale nell'anticaduta per dispositivi di protezione individuale, sistemi e ancoraggi.

Capital Safety är globala inom utrustning, system och förankringar för fallskydd.

### EUROPE, MIDDLE EAST & AFRICA

#### UK

5a Merse Road, North Moons Moat  
Redditch, B98 9HL, UK  
t: +44 (0) 1527 548 000  
f: +44 (0) 1527 591 000

#### FRANCE

Le Broc Center, Bâtiment A  
Z.1. 1re Avenue – BP15  
06511 Carros Le Broc, Cedex, FRANCE  
t: +33 (0) 4 97 10 00 10  
f: +33 (0) 4 93 08 79 70

#### GERMANY

Hagener Straße 44  
57489 Drolshagen, GERMANY  
t: +49 (0) 2 76 18 33 82 29  
f: +49 (0) 2 76 18 33 81 93

#### DUBAI

P.O. BOX 17769, Jebel Ali Free Zone  
Jafza Lobby N° 15, Office N° 15315  
(3rd Floor), DUBAI – UAE  
t: +971 (0) 4 88 11 4 66  
f: +971 (0) 4 88 11 4 67

All rights reserved. The material contained herein is copyrighted; no part of this publication may be reproduced, stored in a retrieval system, or transmitted, in any form or by any means, electronic, mechanical, photocopying, recording or otherwise without prior written permission from Capital Safety.  
Capital Safety Group (Northern Europe) Limited, 3M Centre, Cain Road, Bracknell, Berkshire, RG12 8HT.  
Registered in England and Wales No. 1918922.

### CUSTOMER SERVICES

00 800 999 55500

information@capitalsafety.com

capitalsafety.com



@CapitalSafetyUK  
facebook.com/CapitalSafety  
youtube.com/CapitalSafetyEMEA

A01DBIADVCBEN - 2016