

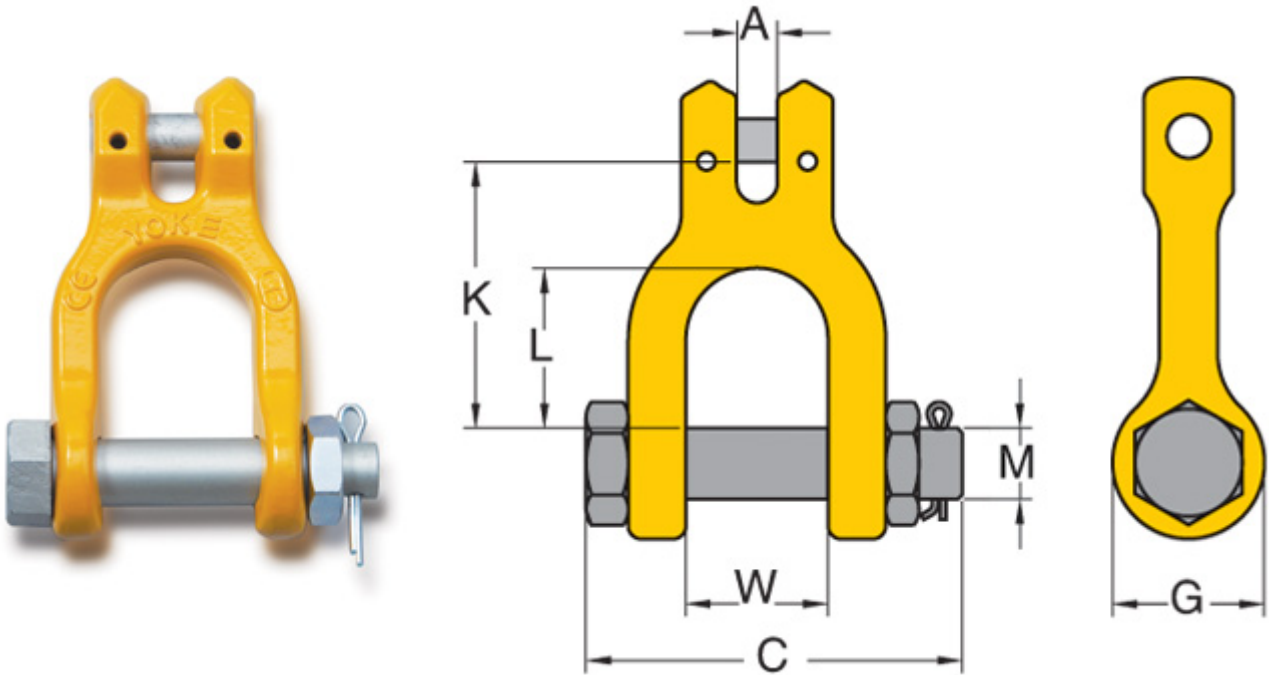

Yoke Grade 8 Clevis Shackle BS EN 1677-1+2

The William Hackett Grade 8 forged lifting components are manufactured by YOKE from alloy steel in accordance with EN1677. All forged components are individually magnaflux crack detected after heat treatment, they are then individually proof load tested to 2.5 times working load limit in accordance with EN1677. Only components fully compliant with all aspects of EN1677 can be used in chain slings certified to EN818-4. The William Hackett Grade 8 lifting components are suitable for use in a temperature range of -40°C up to 200°C without reduction in working load limit.



METRIC SPECIFICATIONS

Part Code	Chain Size mm	A mm	C mm	G mm	K mm	L mm	M mm	W mm	WLL tonnes	Box Qty	Mass Kg
8-066-07	7, 8	9	79	34	59	35	16	33	2.00	35	0.40
8-066-10	10	11	93	40	78	48	20	34	3.15	20	0.80
8-066-13	13	14	118	44	98	64	22	49	5.30	18	1.40
8-066-16	16	18	141	54	112	69	28	60	8.00	10	2.40

IMPERIAL SPECIFICATIONS

Part Code	Chain Size inch	A inch	C inch	G inch	K inch	L inch	M inch	W inch	WLL lbs	Box Qty	Mass lbs
8-066-07	1/4 - 5/16	0.35	3.11	1.34	2.32	1.38	0.63	1.30	4500	35	0.90
8-066-10	3/8	0.43	3.66	1.57	3.07	1.89	0.79	1.46	7100	20	1.80
8-066-13	1/2	0.55	4.65	1.73	3.86	2.52	0.87	1.93	12000	18	3.10
8-066-16	5/8	0.71	5.55	2.13	4.41	2.72	1.10	2.36	18100	10	5.50

