



TM-150-D-A-XL

TRANSMOBIL TM Installation Carrier

A compact universal machine – transport and handling of palletized building material and vacuum installation all in one.

With a dead weight of approx. 1,600 kg (3525 lbs) only, transportation is done easily with a standard trailer.

The powerful vacuum laying unit allows the immediate installation of heavy construction elements – effortless and without physical strain.

The lifting unit is equipped with 2 fork tines. Working length 1,090 mm (43”), horizontally adjustable.

Lifting height of the lifting unit 340 mm (13 1/2”), lifting capacity 1,500 kg (3,300 lbs).

For maximum pallet-width of 1,300 mm (51”).

Dimensions: Overall width 1,910 mm (75”). Total height in transporting position 2,280 mm (90”).

Total length in transporting position 2,300 mm (91”).

We offer two models:

TM-150-D-A-XL: with sound insulated Hatz Silent Pack diesel engine.

TM-150-D-A-SILENT-XL: with sound insulated Hatz Silent Pack diesel engine with additional soundproofing measures. Noise emission < 80 dB.

Both models are equipped with electronic, fully automatic boom alignment – makes work even quicker and particularly user-friendly. Positioning of laying elements without physical effort.



TM-150-D-A-XL

Type	Type of Drive Diesel Engine kW	Load Extension mm (in)	Weight Dead Weight kg (lbs)	Payload kg (lbs)	Working Load Limit/WLL kg (lbs)	Order-Number
TM-150-D-A-XL	9.6	3,000 (118)	1,576 (3,450)	1,500 (3,300)	150 – 250 (330 – 550)	52220012
TM-150-D-A-SILENT-XL	9.6	3,000 (118)	1,689 (3,700)	1,500 (3,300)	150 – 250 (330 – 550)	52220014
TM-150-D-A-XL*	9.6	3,000 (118)	1,595 (3,500)	1,500 (3,300)	150 – 250 (330 – 550)	52220015
TM-150-D-A-SILENT-XL*	9.6	3,000 (118)	1,710 (3,750)	1,500 (3,300)	150 – 250 (330 – 550)	52220016

*Expected to be available as of 2nd quarter 2022

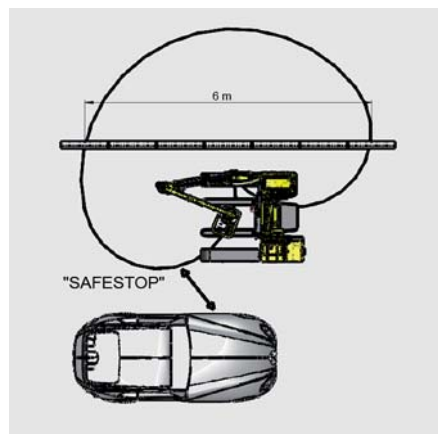

"SAFESTOP" prevents uncontrolled slewing of the articulated boom"

- Mostly kerb stones are installed one side of the road, whilst on the other side vehicles are still allowed to drive. Knuckle boom jib with „SAFESTOP“ never reaches into the traffic area.
- Robust vacuum lifting unit 150 kg (330 lbs) capacity HE-150 and Operating valve unit BE-Sprint-2, can be taken off the unit by quick release connections, for example during the night (protection against vandalism).
- The mast of the vacuum laying unit can be adjusted precisely vertically to allow positioning of the lifting unit light as a feather alongside the perfectly horizontal jib. Adjustment approx. +/- 5 degree sideways, +/- 10 degree in driving direction.
- Compact transportation measurements. The jib is lowered down without manual power via a hydraulic cylinder.
- Quick and simple locking of both knuckle boom links by operating just one lever.
- Hour meter and ignition switch (safeguard in regards of insurance).
- Robust, powerful rubber crawler track – thus the TRANSMOBIL™ maneuvers well and unfailing even on rough terrain. Travel speed approx. 2,2 km/h (1,4 mph).
- Driven by powerful vacuum turbine, also lifts porous materials.
- With more powerful lifting hose unit, proper suction plate etc. and platform for counterweight TM-GGP upgradeable to 200 kg (440 lbs) lifting capacity when fully extended and up to 250 kg (550 lbs) at reduced outreach of 500 mm (19½ inch).
- **New:** With reinforced boom, 250 kg (550 lbs) payload is possible **at full extension**. (only art. no. 52220015 and 52220016).

Accessories:

Type	Description	Weight Dead Weight kg (lbs)	Payload kg (lbs)	Order-Number
TM-GGP	Essential add-on once the lifting capacity exceeds 150 kg (330 lbs). Installation material, such as kerb stones serve as counterweight.	9.2 (20)	250 (550)	42220070

For suction plates see page 104 – 107 or contact us for professional advice.