

Xgard ASU

Xgard Air Sampling Unit (ASU)

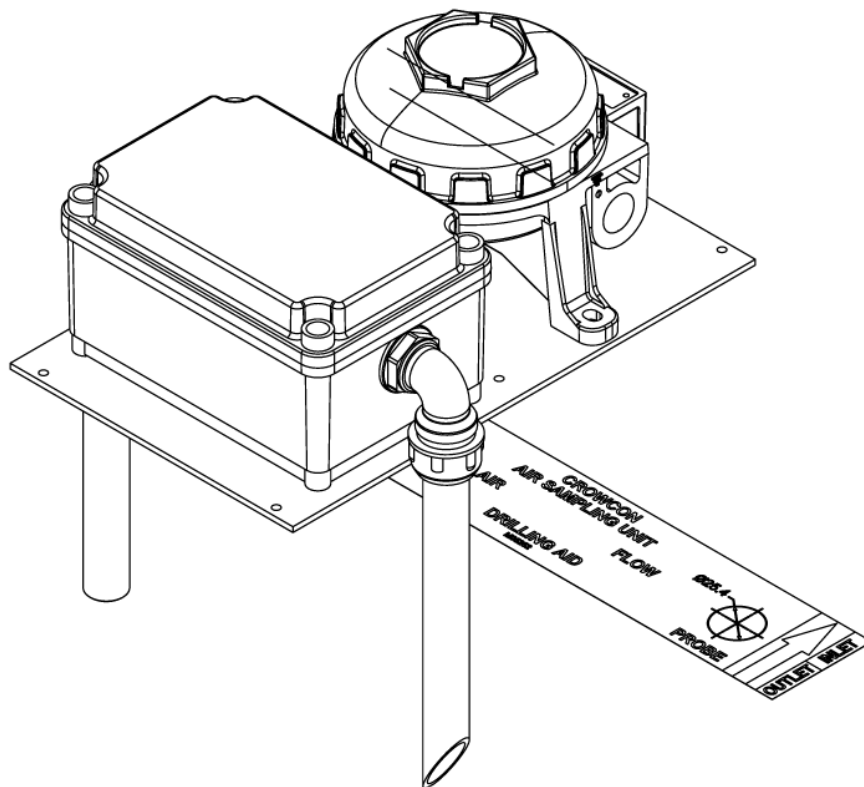

Installation, Operation and Maintenance Instructions

M07646

Issue 9

September 2016

Introduction

The Air Sampling Unit (ASU) is designed to be used with Crowcon's Xgard range of detectors for monitoring potentially hazardous gases within ventilation ducts. The ASU operates using the Venturi principle, for which the air flow rate within the duct must be between 5 metres per second and 20 metres per second.

Installation

The Xgard gas detector must be fitted to the ASU prior to assembly onto the duct. A full assembly drawing is shown on the next page. The ASU is not compatible with the Xgard Type 4 high temperature gas detector.

1. To avoid the adverse effects of turbulence, the ASU should be installed in the centre of a straight section of duct which has a length of at least six times its width.
2. Check the air flow direction in the air duct system.
3. Apply the drilling template onto the centre line of the air duct parallel to the air flow. Check that the directional arrow on the drilling template is the same as the direction of the air flow in the duct.
4. Using a centre punch, punch the two centres indicated for the drilling template.
5. Drill out to 25mm (1") diameter. Remove burrs and sharp edges around the two holes.
6. Remove the ASU cover.
7. Fit the sample tube elbows with rubber washers on the inside and outside of the sampling chamber. Fit the securing nuts and tighten. Ensure that the black sample tube holes face 180° away from the sample chamber, and the white sample tube chamfer faces away from the sample chamber as shown on the diagram on the next page.
8. Check the thickness of the air duct metalwork and fit the black rubber grommets into the two duct holes drilled for point 5 of these instructions.
9. Fit the ASU probes through the two grommets checking that the inlet and outlet probes are correctly installed and push until the unit has sealed.
10. Mark the six ASU plate fixing holes and drill 5mm (1/4") holes for securing the plate. Secure the plate to the duct using suitable bolts.
11. Connect the detector cable as instructed in the Xgard manual.
12. **Check that there is no air leakage into the sampling chamber from outside the duct through the probe joints, grommets or sampling unit cover gasket.**

Testing and Commissioning

Calibrate the detector according to its instructions. Testing the operation of the ASU can be performed by introducing gas into the duct system.

Warning: it is essential to ensure that procedures are in place to prevent people and/or equipment being affected by any test gas introduced into the ventilation system.

Operation and maintenance

The ASU needs no specific maintenance however the Xgard gas detector must be maintained in accordance with its instructions.

Specifications

Xgard ASU Part Number:	S011843
Suitable Duct Widths:	300mm (12") to 1500mm (60")
Suitable Air Speeds:	5 metres (3'3") to 20 metres (13') per second
Operating Temperature Range:	0°C (32°F) to +60°C (140°F)

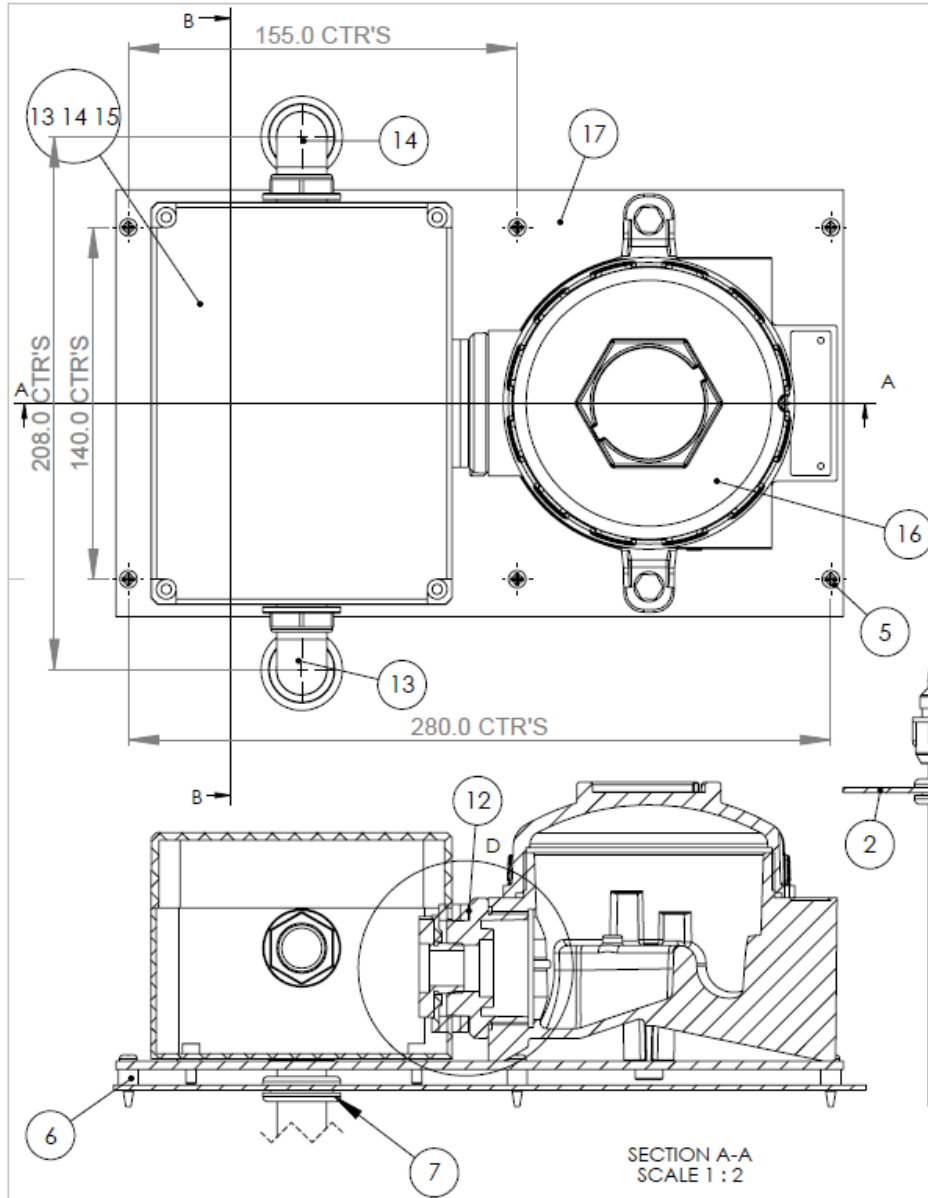

ITEM NO.	QTY.	DESCRIPTION	Drawing No	Stock Number	Comments
1	3	ESU INTERFACE GASKET	GEN-3060-A4	M04876	
2	1	SAMPLING DUCT			
3	2	M6 PLAIN WASHER		M03437	
4	2	M6x16 HEX HEAD BOLT		M03674	
5	6	No 6 x 3/4" SELF TAPPING SCREW		M03683	
6	6	SPACER		M01209	
7	2	SEALING GROMMET			PART OF ASU KIT M01883
8	4	M4x12 CAP HEAD BOLT		M03572	
10	1	RETAINER ADAPTOR	GEN-3062-A3	M04873	
11	1	ESU/ASU Special Washer Detail	GEN-3059-A4	M04874	
12	1	SHIM		M04764	DRILL CENTRE TO 40mm
13 14 15	1	AIR SAMPLING UNIT ASSEMBLY	MCAD-001739	M01883	
16	1	XGARD DETECTOR			
17	1	ASA MOUNTING PLATE	MCAD-003399	M071033	

- NOTES
1. ENSURE SEAL BETWEEN X GARD DETECTOR ITEM AND ASU ITEM IS GAS TIGHT BEFORE SECURING XGARD TO MOUNTING PLATE
 2. USE DRILLING AID AID M05252 FOR CORRECT POSITION OF PIPE CENTRES IN DUCT
 3. WHEN MOUNTING UNIT TO DUCTING ENSURE SPACERS ITEM 10 ARE FITTED

Stock No.
S011843

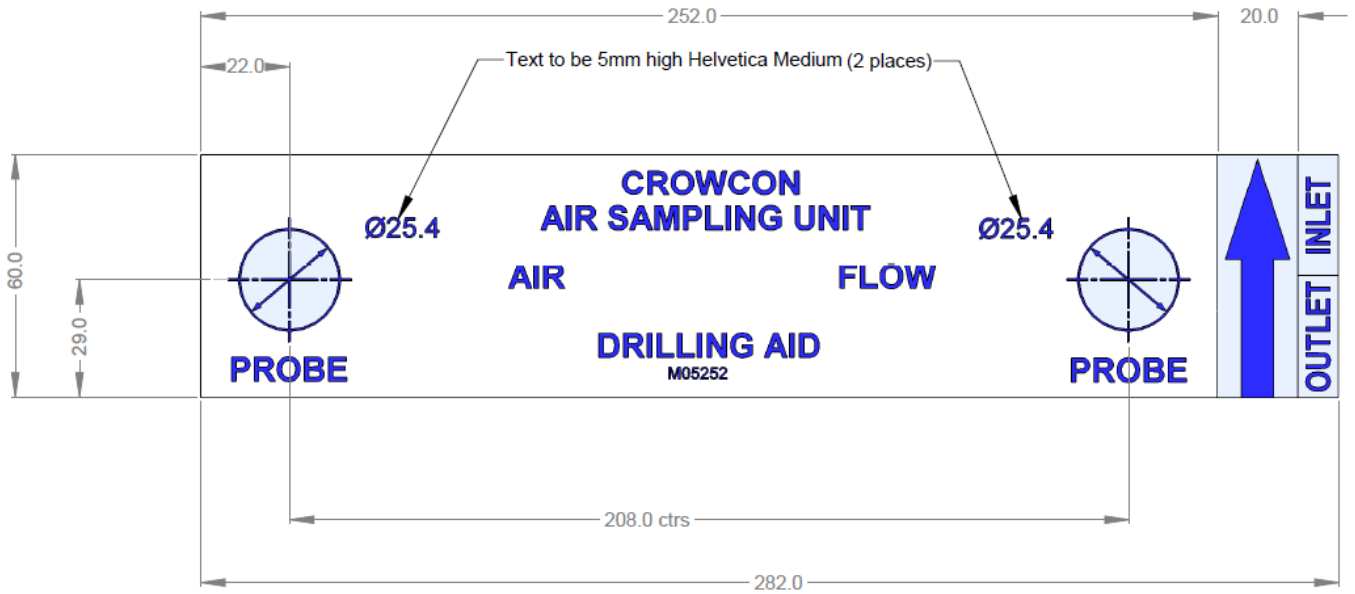

Drilling Template Label Dimensions



A HALMA COMPANY

© Crowcon Detection Instruments Ltd 2016

UK Office
 Crowcon Detection Instruments Ltd
 172 Brook Drive,
 Milton Park,
 Abingdon
 Oxfordshire OX14 4SD
 Tel: +44 (0)1235 557700
 Fax: +44 (0)1235 557749
 Email: sales@crowcon.com
 Website: www.crowcon.com

USA Office
 Crowcon Detection
 Instruments Ltd
 1455 Jamike Ave, Suite 100
 Erlanger
 Kentucky 41018
 Tel: +1 859 957 1039 or
 1 800 527 6926
 Fax: +1 859 957 1044
 Email: salesusa@crowcon.com
 Website: www.crowcon.com

European Office
 Crowcon Detection Instruments Ltd
 Vlambloem 129
 3068JG
 Rotterdam
 Netherlands
 Tel: +31 10 421 1232
 Fax: +31 10 421 0542
 Email: eu@crowcon.com
 Website: www.crowcon.com

Singapore Office
 Crowcon Detection
 Instruments Ltd
 Block 194 Pandan Loop
 -06-20 Pantech Industrial Complex
 Singapore 128383
 Tel: +65 6745 2936
 Fax: +65 6745 0467
 Email: sales@crowcon.com.sg
 Website: www.crowcon.com

China Office
 Crowcon Detection Instruments Ltd
 (Beijing)
 Unit 316, Area 1, Tower B, Chuangxin
 Building
 12 Hongda North Road, Beijing Economic
 Technological Development Area
 Beijing, China 100176
 Tel: +86 10 6787 0335
 Fax: +86 10 6787 4879
 Email: saleschina@crowcon.cn
 Website: www.crowcon.com