

# Operation and Service Manual for HERMetric UTImeter Otex

Portable Electronic Open Gauging Device  
Ullage - Temperature - Interface detector



**Note :**  
before using the  
instrument please  
read this book.



# 1. Table of contents

<b>1.</b>	<b>TABLE OF CONTENTS .....</b>	<b>2</b>
<b>2.</b>	<b>GENERAL INFORMATION .....</b>	<b>4</b>
2.1	SHIPMENT NOTE.....	4
2.2	INITIAL INSPECTION.....	4
2.3	DOCUMENTATION DISCREPANCIES.....	4
2.4	WARRANTY .....	4
2.5	CERTIFICATION.....	5
2.6	SPARE PARTS .....	5
2.7	SERVICE AND REPAIR .....	5
<b>•</b>	<b>WORLDWIDE SERVICE STATIONS</b>	
	<b>NETWORK.....</b>	<b>7</b>
<b>4.</b>	<b>RECOMMENDATION FOR SAFE USE.....</b>	<b>7</b>
<b>5.</b>	<b>FUNCTIONS - KEY FEATURES.....</b>	<b>10</b>
<b>6.</b>	<b>DESCRIPTION.....</b>	<b>11</b>
6.1	GENERAL .....	11
6.2	ULTRA SENSING PROBE .....	13
6.2.1	Introduction .....	13
6.2.2	Ullage detection.....	13
6.2.3	Interface detection .....	14
6.2.4	Temperature measurement.....	14
6.3	TAPE.....	15
6.4	READING INDEX .....	16
	<i>UTImeter Otex standard version</i> .....	16
	<i>UTImeter Otex visc version</i> .....	16
6.5	TAPE CLEANER .....	17
6.6	ADDITIONAL LOAD (OPTION) .....	18
6.6.1	Viscous liquids (> 800 Cst).....	18
6.6.2	Reference height and innage.....	18
6.7	OTHERS .....	18
<b>7.</b>	<b>OPERATION .....</b>	<b>19</b>
7.1	BASIC RULES CONCERNING THE 5-KEY CONTROL PAD .....	19
7.2	SELECTING THE LANGUAGE.....	20
7.3	SELECTING THE TEMPERATURE SCALE.....	21
7.4	SELECTING THE TEMPERATURE RESOLUTION ..	22
7.5	ACTIVATING THE LED .....	23
7.5.1	<i>Temporary setting of the LED</i> .....	23
7.5.2	<i>Permanent setting of the LED</i> .....	23
7.6	MUTING THE BUZZER .....	24
7.7	BACKLIGHT.....	24
7.8	CHECKING THE FUNCTIONS BEFORE USING THE INSTRUMENT.....	25
7.8.1	<i>Battery</i> .....	25
7.8.2	<i>Reading index</i> .....	25
7.8.3	<i>Temperature</i> .....	25
7.8.4	<i>Ullage</i> .....	25
7.8.5	<i>Interface</i> .....	25
7.9	INSTALLATION OF THE INSTRUMENT .....	26
7.10	ULLAGE /INTERFACE MEASUREMENT .....	26
7.11	REFERENCE HEIGHT / INNAGE MEASUREMENT	27
7.12	TEMPERATURE MEASUREMENT.....	28
<b>8.</b>	<b>CARE AND MAINTENANCE .....</b>	<b>29</b>
8.1	CARE .....	29
8.2	CHECKING THE BATTERY .....	30
8.2.1	<i>Before starting gauging</i> .....	30
8.2.2	<i>During gauging</i> .....	31
8.3	BATTERY REPLACEMENT .....	32
8.4	TAPE REPLACEMENT.....	33
8.4.1	<i>Disconnecting the tape from the sensor</i> 33	
8.4.2	<i>Disconnecting the tape from the electronic box</i> .....	33
8.4.3	<i>Disconnecting the tape from the reel axle</i> 34	
8.4.4	<i>Removing the tape from the frame</i> .....	34
8.4.5	<i>Mounting the new tape</i> .....	34
8.5	SENSING PROBE REPLACEMENT.....	35
8.5.1	<i>Disconnecting the old sensing probe</i> ....	35
8.5.2	<i>Connecting the new sensing probe</i> .....	35
8.6	TAPE WIPERS REPLACEMENT.....	35
8.7	DISPLAY UNIT REPLACEMENT .....	36
8.7.1	<i>Disconnecting the old display unit</i> .....	36
8.7.2	<i>Connecting the new display unit</i> .....	36
8.8	VERIFICATION AND CERTIFICATION OF TAPES. 36	
8.9	VERIFICATION AND ADJUSTMENT OF THE READING INDEX.....	37
	<i>UTImeter Otex Standard Version</i> .....	37
	<i>UTImeter Otex Visc Version</i> .....	37
8.10	TEMPERATURE VERIFICATION .....	37
8.10.1	<i>Equipment required</i> .....	37
8.10.2	<i>Preparing the Ice Point bath</i> .....	37
8.10.3	<i>Checking the UTImeter</i> .....	38
8.11	ULLAGE/INTERFACE VERIFICATION .....	38
<b>9.</b>	<b>TROUBLE SHOOTING .....</b>	<b>39</b>
9.1	SAFETY WARNING .....	39
9.2	POWER SUPPLY TROUBLES.....	39
9.3	TRANSMISSION TROUBLES .....	39
9.4	ULLAGE AND/OR INTERFACE TROUBLES.....	40
9.5	TEMPERATURE TROUBLES .....	40
9.6	VISUAL INSPECTION FOR DAMAGED OR MISSING PARTS .....	40
9.7	COATED ALUMINIUM PARTS .....	41
9.8	ELECTRICAL CHECK OF TAPE ASSEMBLY .....	41

<b>10. SPECIFICATIONS.....</b>	<b>42</b>	11.1 HOW TO PROCEED.....	43
<b>11. SPARE PARTS .....</b>	<b>43</b>	11.2 LIST OF PARTS DESCRIPTIONS.....	43
		11.3 SPARE PARTS DRAWINGS .....	45

## 2. General information

### 2.1 Shipment note

The following parts should be included in the shipment:

- 1 instrument fitted out with one battery in the display;
- 1 set of 4 Allen keys: 1.5, 2, 2.5 and 3 mm;
- 1 Operation and Service Manual.

### 2.2 Initial inspection

Check the contents of the shipment for completeness and note whether any damage has occurred during transport. Carry out the "Initial test before installing the instrument" to verify the good functioning. If the contents are incomplete, or if there is damage, a claim should be filled with the carrier immediately, and Enraf Tanksystem SA Sales or Service organization should be notified in order to facilitate the repair or replacement of the instrument.

### 2.3 Documentation discrepancies

The design of the instrument is subject to continuous development and improvement. Consequently, the instrument may incorporate minor changes in detail from the information contained in the manual.

### 2.4 Warranty

**Two (2) years after installation but max. 30 months after delivery ex works except batteries.**

**The Vendor undertakes to remedy any defect resulting from faulty design materials or workmanship. The Vendor's obligation is limited to the repair or replacement of such defective parts by his own plant or one of his authorized service stations. The Purchaser shall bear the cost and risk of transportation of defective parts and repaired parts supplied in replacement of such defective parts.**

**When returned to Enraf Tanksystem SA or any of its agreed Service Stations equipment must be contamination-free. If it is determined that the Purchasers equipment is contaminated, it will be returned to the Purchaser at the Purchasers expense. Contaminated equipment will not be repaired, replaced, or covered under any warranty until such time that the said equipment is decontaminated by the Purchaser.**

The Purchaser shall notify by fax, telex or in writing of any defect immediately upon discovery, specifying the nature of the defect and/or the extend of the damage caused thereby.

Where no other conditions have been negotiated between the Vendor and the Purchaser "General Conditions 188" of United Nations shall apply.

This instrument has been certified as Intrinsically Safe Instrumentation for only those classes or categories of hazardous areas stated on the instrument label, bearing the mark of the applicable approval authority. No other usage is authorized.

Unauthorized repair or component replacement by the Purchaser will void this guarantee and may impair the intrinsic safety of the instrument. In particular it is not allowed to repair electronic circuits.

In no event shall Enraf Tanksystem SA be liable for indirect, incidental or consequential loss or damage or failure of any kind connected with the use if its products or failure of its products to function or operate properly.

Enraf Tanksystem SA do not assume the indemnification for any accident or damage caused by the operation of its product and the warranty is limited to the replacement of parts or complete goods.

## 2.5 Certification



Enraf Tanksystem SA is an ISO 9001 certified company by Det Norske Veritas Certification GmbH.

The equipment has been approved for the electrical intrinsic safety by the following authorities :

### **ATEX**

II 1 G EEx ia IIB T4 / Tamb. 50 °C

### **Factory Mutual (FM Approvals)**

CL I, DIV 1, GP C&D, T4 Tamb. 50 °C and  
CL I, ZN 0, AEx ia IIB T4 Tamb. 50 °C

If you need a copy of any of these certificates please contact:

Enraf Tanksystem SA  
Rue de l'industrie 2  
1630 Bulle, SWITZERLAND

Telephone : +41-26-91 91 500  
Telefax : +41-26-91 91 505  
Web site : [www.tanksystem.com](http://www.tanksystem.com)  
E-mail : [info@tanksystem.com](mailto:info@tanksystem.com)

## 2.6 Spare parts

When ordering spares identify the spare part by TS number and description. Refer to section 11 "Spare parts".

Some spares might be repairable; in this case send the part(s) to any authorised service center or to the factory.

In case of urgency, complete replacement units can be made available. Contact the factory or nearest Service Station for details.

## 2.7 Service and Repair

The customer is responsible for any freight and customs clearance charges. If units are sent on a "freight collect" the charges will be invoiced to the customer.

When returning units or parts for repair to the factory please fill out a service request form (see next page). The serial number (letter "O" followed by 5 digits) is printed on the identification plate as shown on the Figure 6-1.

When returned to Enraf Tanksystem SA equipment must be contamination-free. If it is determined that the customers equipment is contaminated, it will be returned to the customer at the customers expense. Contaminated equipment will not be repaired until such time that the customer decontaminates the said equipment.

## Service Request

Customer's address: .....  
.....  
.....  
.....  
.....

Telephone: .....

E-mail: .....

Fax: .....

Type of unit or part: .....  
.....

Serial number: .....

Short description of trouble: .....  
.....  
.....  
.....

Do you want a quotation before repair is started:.....yes / no.....

Repaired unit has to be returned to the following address:

.....  
.....  
.....  
.....  
.....

• **Worldwide Service Stations network**

*The updated list can be found on our website [www.tanksystem.com](http://www.tanksystem.com)*

COUNTRY	ADDRESS	TELEPHONE/FAX/E-MAIL
SWITZERLAND	ENRAF TANKSYSTEM SA 2, rue de l'Industrie CH-1630 BULLE	Tel : +41-26-91 91 500 Fax : +41-26-91 91 505 info@tanksystem.com
CANADA	PYLON ATLANTIC A Div. Of Pylon Electronics Inc. 31 Trider Crescent., DARTMOUTH, N.S. B3B 1V6	Tel : +1-902-4683344 Fax : +1-902-4681203 halifax_csr@pylonelectronics.com
CHINA	HUA HAI EQUIPMENT & ENGINEERING CO LTD Factory 7, Lane 1365, East Kang Qiao Road Kang Qiao Industrial Zone, Pu Dong SHANGHAI, P.C. 201315	Tel : +86-21-68183183 Fax : +86-21-68183115 huahaish@huahaiee.com
GREECE	SPANMARIN 86, Filonos Street GR-185 36 PIRAEUS	Tel : +30-210-4294498 Fax : +30-210-4294495 spanmarin@ath.forthnet.gr
JAPAN	DAIWA HANBAI CORPORATION LTD 10-31, Mitejima 2-Chome, Nishiyodogawa-ku OSAKA 555-0012	Tel : +81-6-64714701 Fax : +81-6-64729008 daiwa471@silver.ocn.ne.jp
KOREA	World Ocean CO., LTD Hang-Woon Building 1168-11, Cho Ryang 3 Dong Dong-Ku PUSAN	Tel : +82-51-462-2554/5 Fax : +82-51-462-0468 marine@worldocean.co.kr
MEXICO	URBAN S.A. DE C.V. Ave. Ejército Mexicano 1902 Col. Loma del Gallo 89460 CD. MADERO, TAMPS. MEXICO	Tel : +52-833-2170190 Fax : +52-833-2170190 E-mail : urbansa@prodigy.net.mx
NETHERLANDS	B.V. TECHNISCH BUREAU UITTENBOGAART Brugwachter 13 NL-3034 KD ROTTERDAM	Tel : +31-10-4114614 Fax : +31-10-4141004 info@tbu.nl

The updated list can be found on our website [www.tanksystem.com](http://www.tanksystem.com)

COUNTRY	ADDRESS	TELEPHONE/FAX/E-MAIL
PORTUGAL	CONTROLIS Soc. Com. Equipamentos de Controlo, Lda. Rua Conceição Sameiro Antunes, 26E P-2800 COVA DA PIEDADE	Tel : +351-21-2740606 Fax : +351-21-2740897 controlis@netc.pt
RUSSIA	NPP "GERDA" Vilisa Latsisa str. 17 Building 1 125480 MOSCOW	Tel : +7-095-7558845 Fax : +7-095-7558846 info@gerda.ru
SINGAPORE	HUBBELL INT'L (1976) PTE LTD 322 Thomson Road SINGAPORE 307665	Tel : +65-6-2557281 Tel : +65-6-2550464 Fax : +65-6-2532098 hubbell@mbox2.singnet.com.sg
SPAIN	E.N.I. Electronica y Neumatica Industrial, S.A. C/Jon Arrospide, 20 (Int.) 48014 BILBAO	Tel : +34-94-4746263 Fax : +34-94-4745868 eni.tecnica@eni.es
SWEDEN	INSTRUMENTKONTROLL Lars Petersson AB Varholmsgatan 1 414 74 GÖTEBORG	Tel : +46-31-240510 Tel : +46-31-240525 Fax : +46-31-243710 Info@instrumentkontroll.se
UNITED ARAB EMIRATES	MARITRONICS P.O. Box 6488 DUBAI	Tel : +971-4-3247500 Fax : +971-4-3242500 maritron@emirates.net.ae
UNITED KINGDOM	ENERGY MARINE (INTERNATIONAL) LTD. 12 Clipstone Brook Industrial Estate Cherrycourt Way LEIGHTON BUZZARD, BEDS LU7 8TX	Tel : +44-1525-851234 Fax : +44-1525-852345 info@engmar.com
U.S.A/ TEXAS	HERMETIC, INC. 4522 Center Street DEER PARK, TX 77536	Tel: +1-281-930 1777 Fax: +1-281-930 1222 Toll free call in the USA: 1-800-900 1778 info@hermeticinc.com



## 4. Recommendation for safe use

1. This Operation and Service Manual is a guide in order to help the user to operate the instrument to our best knowledge.
2. Nevertheless the maker disclaims all responsibility and liability for damage resulting from the use of the equipment regardless of the cause of the damage.
3. **Attention is drawn to the possible hazard due to electrostatic charges which may be present in the tank.** This may happen in particular with static accumulator liquids, i.e. liquids which have low conductivity of 50 picoSiemens/metre (pS/m) or less.
4. **It is very important that the instrument is grounded to the tank before the probe is introduced into the tank and remains grounded until after complete withdrawal from the tank.**
  - 4.1. **The instrument has to be also earthed by means of the grounding cable and clamp.** Attention is drawn to the fact that paint coatings and oxidised parts are insulating. Connect the instrument to a grounded conductive part of the tank with the grounding cable.
5. **It is anticipated that the user will have specific operating methods laid down to ensure safety when using this type of apparatus. In this case the user's instructions shall be strictly observed.**
6. **In the absence of such instructions the following should be noted:**
  - 6.1. If a metal sounding pipe is fitted beneath the deck valve or tank is inerted, then ullaging, etc. is permissible at any time with no restriction.
  - 6.2. If there is no sounding tube or tank is not inerted, the following precautions shall be taken:
    - 6.2.1. If the cargo is not a static accumulator liquid, i.e. its conductivity is more than 50 pS/m, then ullaging is permitted provided that the instrument is properly grounded and earthed before the probe is inserted into the tank and remains earthed until the probe has been removed from the tank.
    - 6.2.2. If the cargo is a static accumulator liquid, i.e. its conductivity is less than 50 pS/m, then ullaging is permitted provided that:
      - 6.2.2.1. The instrument is properly grounded and earthed before the probe is inserted into the tank and remains earthed until the probe has been removed from the tank.
      - 6.2.2.2. The apparatus is not introduced into a tank until at least 30 minutes have elapsed after completion of any loading operation or stopping the injection of inert gas.
  - 6.3. For further guidance refer to International Safety Guide for Oil Tankers and Terminals (ISGOTT), ISBN 1 85609 081 7, Fourth Edition 1996, or consult the appropriate Legislative Authority for the installation.
7. **Warning: change of battery must be carried out in safe area only (non flammable atmosphere).**

## 5. Functions - Key Features

This HERMeTic instrument is a portable multiple functions gauging system that is designed to perform under open conditions in a single operation 3 measurements:

- a) Ullage (outage). Optionally innage is available<sup>1</sup>.
- b) Oil/water Interface level.

Tape resolution: 1 mm (1/16")

Tape accuracy:  $\pm 1.5$  mm over 30 m  
( $\pm 1/16$ " approx. for 100 feet)

Ullage/interface detection accuracy:  
 $\pm 2$  mm ( $\pm 0.08$ " approx.)

Minimum detectable tank bottom interface or liquid level: 4 mm (0.16" approx.).

- c) Temperature by continuous reading at any level.

Ambient temperature range:  $-20^{\circ}\text{C}$  to  $50^{\circ}\text{C}$   
( $-4^{\circ}\text{F}$  to  $122^{\circ}\text{F}$ )

Sensor measurement range:  $-40^{\circ}\text{C}$  to  $90^{\circ}\text{C}$   
( $-40^{\circ}\text{F}$  to  $194^{\circ}\text{F}$ )

Resolution:  $0.01^{\circ}$  or  $0.1^{\circ}$ , selectable

Accuracy over calibration range:  $\pm 0.1^{\circ}\text{C}$  ( $0^{\circ}\text{C}$  to  $70^{\circ}\text{C}$ );  $\pm 0.2^{\circ}\text{F}$  ( $32^{\circ}\text{F}$  to  $158^{\circ}\text{F}$ )

Temperature reading:  $^{\circ}\text{C}$  or  $^{\circ}\text{F}$ , selectable.

This HERMeTic device meets the requirements of API MPMS Chapter 7 2001, table 3, ISO 4268 and IP PMM Part IV.

Thanks to the small diameter of the sensing probe this instrument can be used with openings of diameters down to 25 mm (1") only.

<sup>1</sup> An additional device can be provided that allows **Reference Height** and **Innage** measurement. Available on "Visc" models.

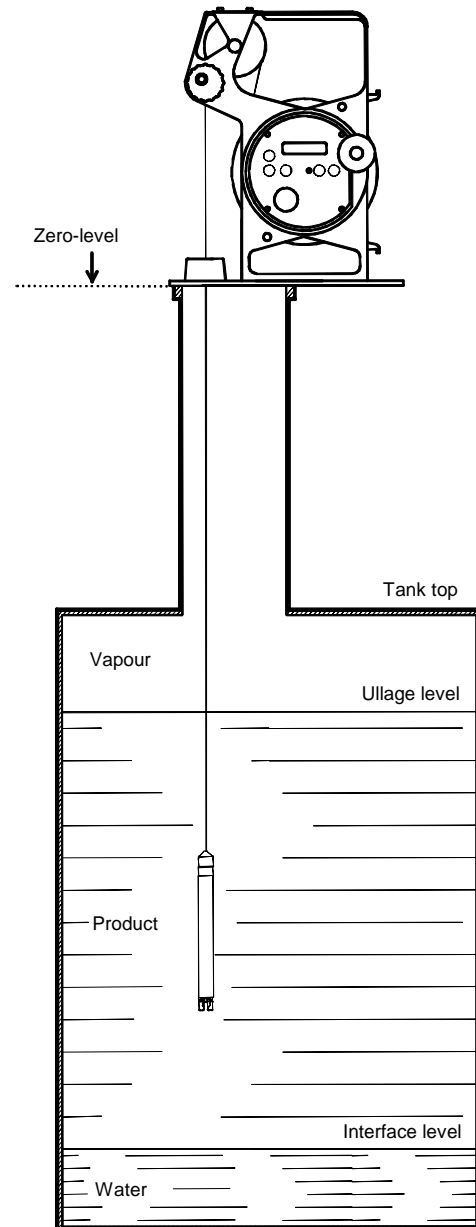

## 6. Description

### 6.1 General

Each HERMetic instrument is **individually identified** with a 6 digits serial number starting with the letter O, example O10058. This serial number is printed on the identification plate that as shown on Figure 6-1.

The HERMetic instrument is fitted with an **ULTRA** sensing probe.

The unit emits control beep, continuous beep and intermittent beep.

When the sensing probe is surrounded by air, a control beep occurs every 2 sec.

When the sensing probe is in contact with any petroleum product, the beep is continuous.

When the sensing probe is in contact with water the beep is intermittent.

Control beep	•	•
Continuous beep	• • • • •	• • • • •
Intermittent beep	• • •	• • •

A light signal (LED) can also be activated that blinks at the same frequency as the buzzer tones. This can be useful in noisy environments or at night.

A backlight can be used at night to light up the display.

The HERMetic instrument is powered by a 9 Volt battery stored in the electronic terminal named instrument unit. Current consumption is very low, ensuring long operation without battery replacement. **A continuous tone means that the battery needs replacement.** If the battery power is too low, it is no more possible to read the temperature.

**Maintenance is easy** because design is modular and allows quick exchange of parts.

See also Figure 6-2 to get to know the equipment.

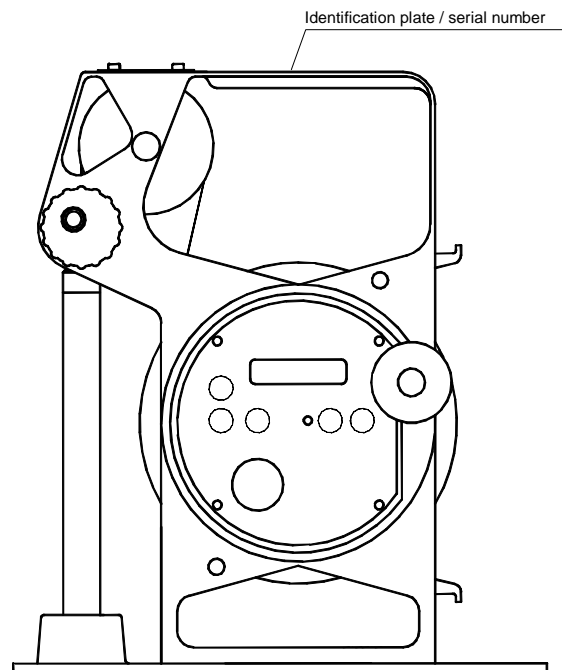

**Figure 6-1**

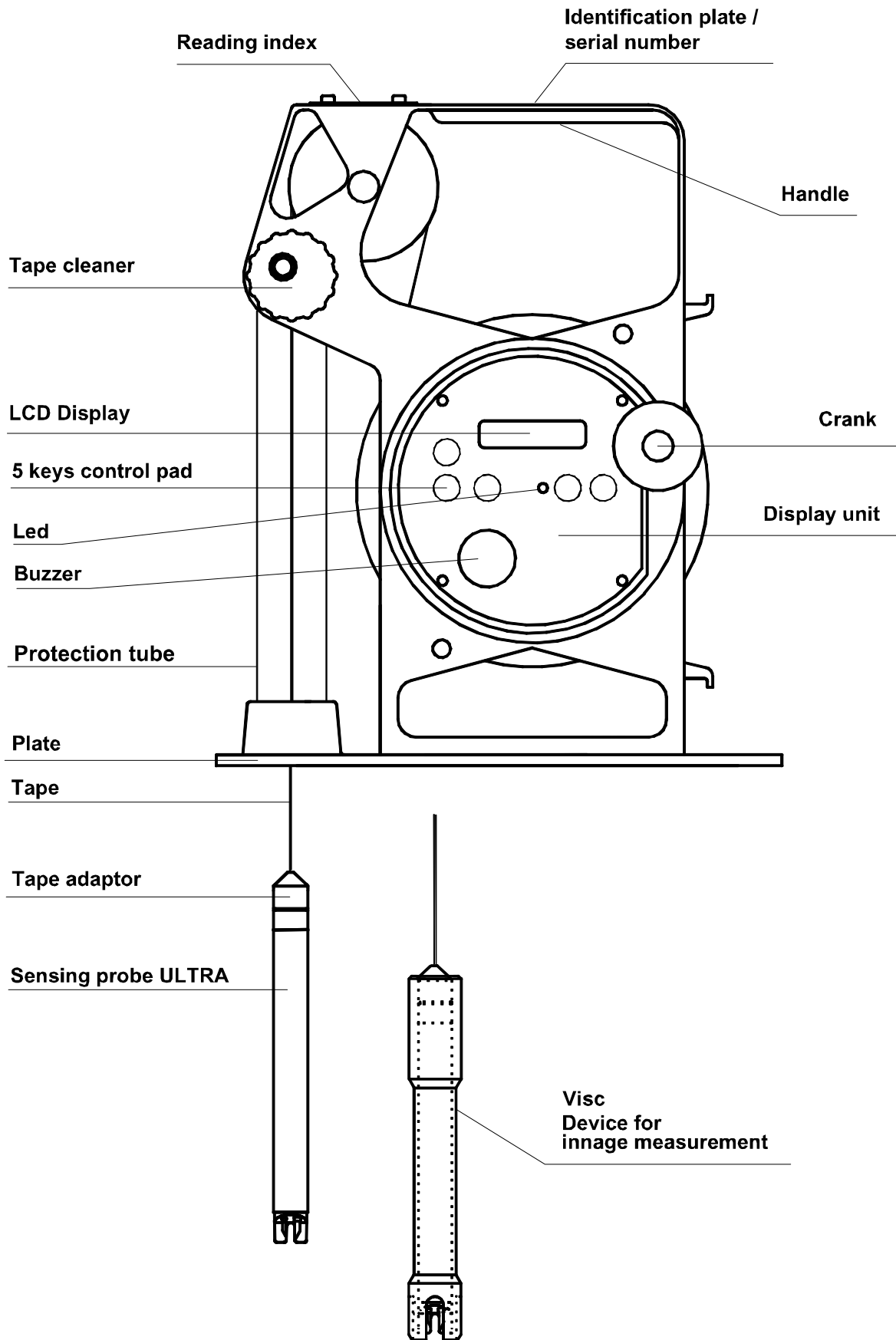

Figure 6-2

## 6.2 ULTRA sensing probe

### 6.2.1 Introduction

The ULTRA sensing probe consists of a stainless steel tube terminated by a high-tech plastic head which cannot be removed from the tube. The sensing probe includes an ultrasonic liquid level sensor, a temperature sensor and a conductivity electrode. The sensitivity for ullage and interface measurement is not adjustable. The temperature measurement is calibrated at the factory and does not require subsequent adjustment.

### 6.2.2 Ullage detection

The ullage detector consists of two piezoceramic plates and electronic circuits. When the sensor head is immersed in a non-conductive liquid (oil or petroleum), the emitted ultrasonic signal is detected by the receiver, coded and sent to the instrument unit which activates the buzzer with the continuous beep.

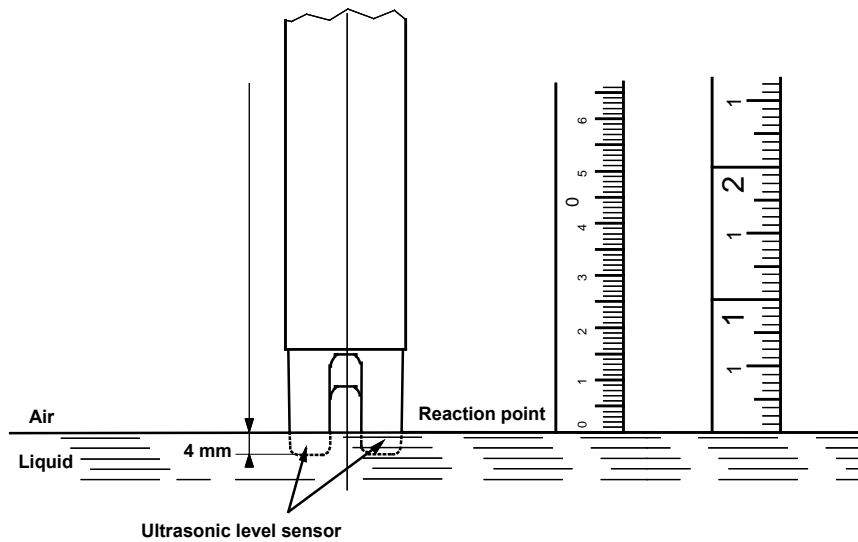

Figure 6-3

The reaction point is located 4 mm (5/32") from the sensor bottom and identical with the zero-point of the tape graduation.

### 6.2.3 Interface detection

The principle consists of a conductivity measurement between an active electrode and a grounded electrode. When the liquid is conductive (as water), the ullage sensor detects the presence of

the liquid as well and the conductivity electrodes and associated electronic circuits modulate the coded signal to generate the intermittent beep.

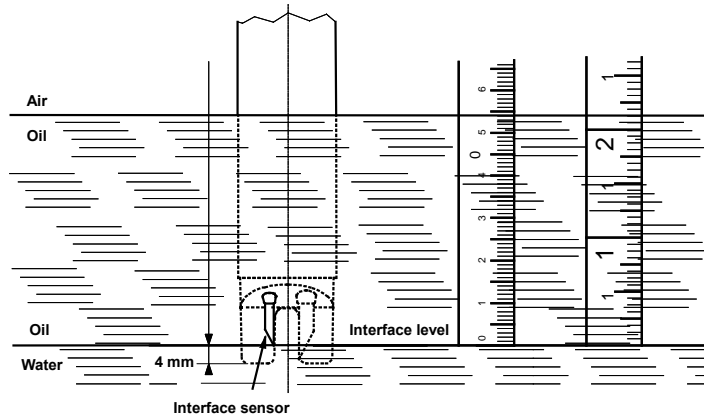

Figure 6-4

The reaction point is located 4 mm (5/32") from the sensor bottom and identical with the zero-point of the tape graduation.

### 6.2.4 Temperature measurement

The sensing element is a Platinum Resistance Temperature Detector (RTD) element. The element is located in the temperature electrode, which is filled in with a heat transfer compound paste to reduce the response time. The RTD element signal is digitized, and then all errors (offset, non-linearity and drift) are corrected and compensated by the micro-controller located in the sensor probe. The RTD element characteristics are stored in the sensor memory

and are dedicated to one sensor. For this reason, changing a sensor does not require a new calibration.

All data are serialised and sent by the micro-controller to the Display Unit. Temperature settings (resolution, scale) are easy selectable by pressing the 5-key control panel.

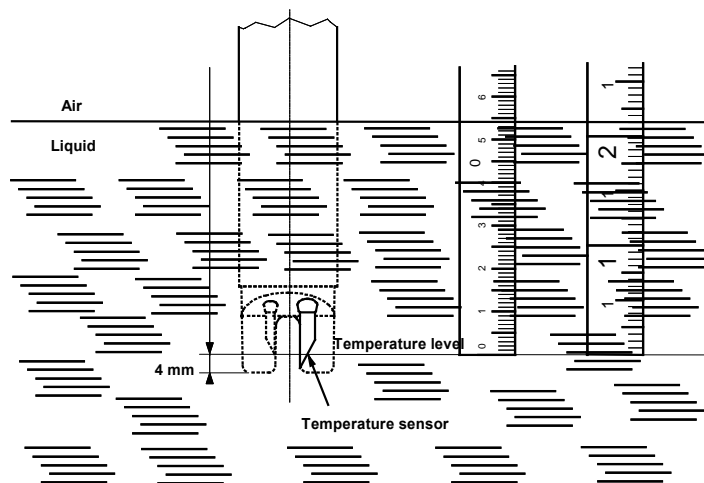

Figure 6-5

The reaction point is located 4 mm (5/32") from the sensor bottom and identical with the zero-point of the tape graduation.

### 6.3 Tape

The ETFE (TEFZEL) coated tape provides 3 main functions :

- It holds the sensing probe.
- It is graduated and therefore makes it possible to determine the distance between the reaction point and the reading index. If the reading

index is set up at the zero ullage level, the reading of the tape is identical to the ullage.

- It contains 2 wires for transmitting the signal and the power between the display unit and the probe. The steel tape itself is used as a grounding wire between the sensing probe tube and the display unit.

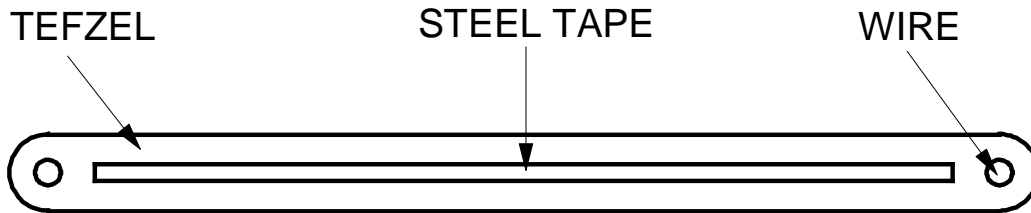

Figure 6-6

The standard graduation is a double side type that shows the metric graduation on one side and the inch one on the other side. The tape is mounted on the equipment according to the need.

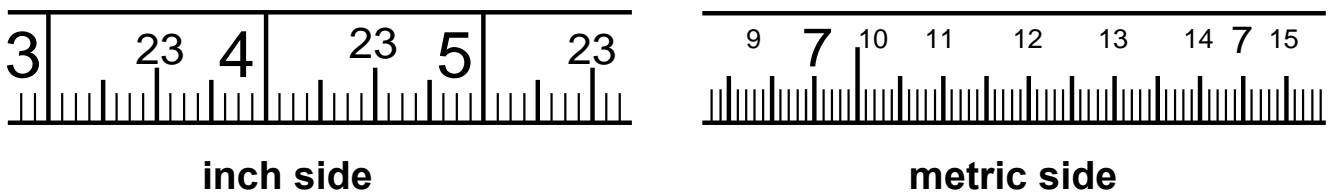

Figure 6-7

## 6.4 Reading index

### UTImeter Otex standard version

The reading index shows “zero” when the reaction point of the sensing probe coincides with the bottom of the plate. As the reaction point is 4 mm recessed from the probe bottom the reading index shows zero when the sensing probe is 4 mm below the plate, as shown on Figure 6-8. For more details refer to section 8.9 "Verification and adjustment of the reading index".

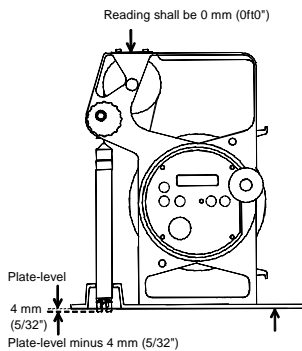
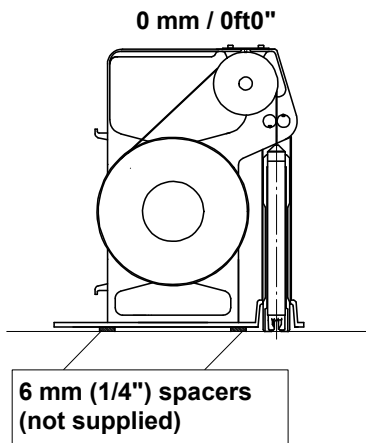

Figure 6-8

### UTImeter Otex visc version

The reading index shows “zero” when the reaction point of the sensing probe coincides with the bottom of the plate. As the reaction point is 6 mm recessed from the additional load bottom the reading index shows zero when the sensing probe is 6 mm below the plate. For more details refer to section 8.9 "Verification and adjustment of the reading index".



If the instrument is installed in such a way that the bottom of the plate is at the same level as the zero-ullage reference level then the reading of the tape corresponds to the ullage when the reaction point of the sensing probe is positioned at the liquid level, as shown on Figure 6-9.

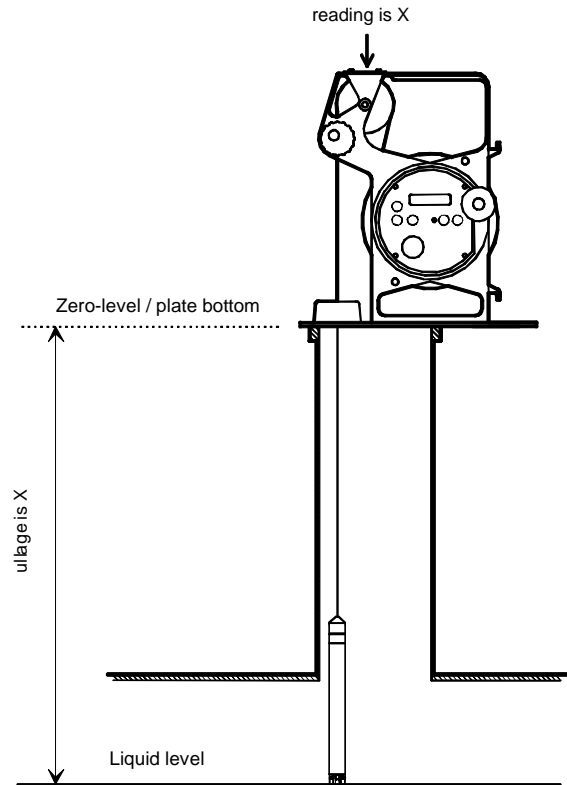

Figure 6-9

If the bottom of the plate is positioned below or above the zero reference level a positive or negative correction of the tape reading is necessary.



### 6.5 Tape cleaner

This HERMetic equipment is fitted with a tape cleaner that helps draining the liquid back to the tank when rewinding the tape. It is very easy to operate:

- position "DOWN": the wipers are not working, the tape is free;
- position "UP": the wipers are cleaning the tape.

Refer to Figure 6-10.

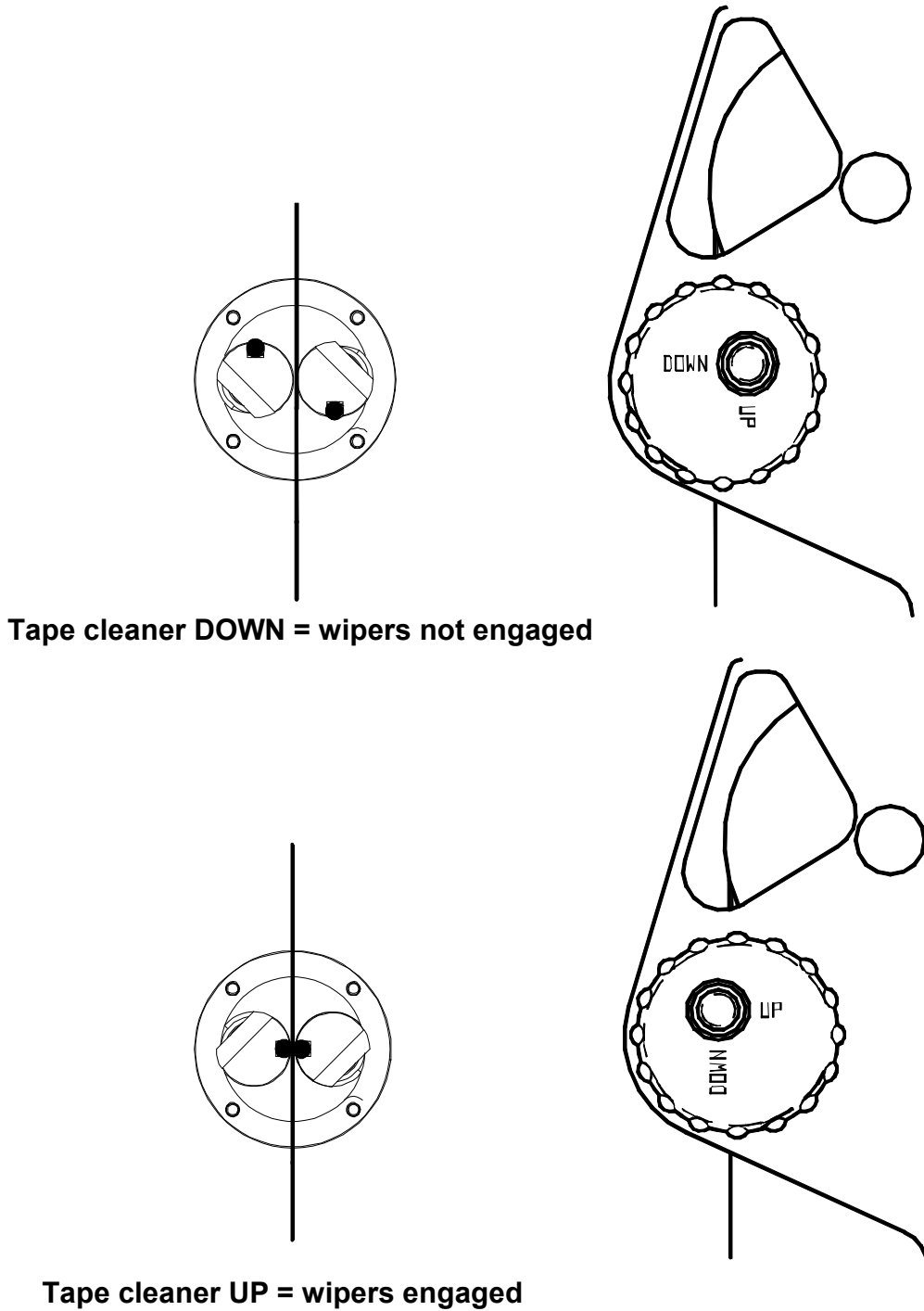

Figure 6-10

## **6.6 Additional Load (option)**

An additional load (see Figure 6-2) on the sensing probe can be provided for one of the following reasons.

### **6.6.1 Viscous liquids (> 800 Cst)**

For gauging viscous liquids the load can help the sensing probe in penetrating the liquid and in keeping the tape straight.

### **6.6.2 Reference height and innage**

For measuring the reference height of a tank and innages the load allows the sensing probe to touch the dip/datum plate. When fitting the unit with the additional load, it is required to adjust the reading index

## **6.7 Others**

The tape is coiled on the reel axle which holds also the electronic display unit.

The axle is assembled to the electronic box and can be locked at discrete positions by means of a stopping mechanism in the crank. Pull the crank to free the stopping mechanism.

The frame and the plate are made in aluminium coated with polyamid PA 11 (RILSAN).

## 7. Operation

### 7.1 Basic rules concerning the 5-key control pad

Apart from the "ON" / "OFF" keys that are self-explanatory, there are 3 other keys that help in customising the unit:

- pressing "+" allows to scroll down the menus, a pointer show the actual menu you have selected,
- pressing "-" allows to exit a menu,

- pressing "enter" (later on named "E") allows to enter a specific menu.

The small pointer displayed on the left is showing the active setting.

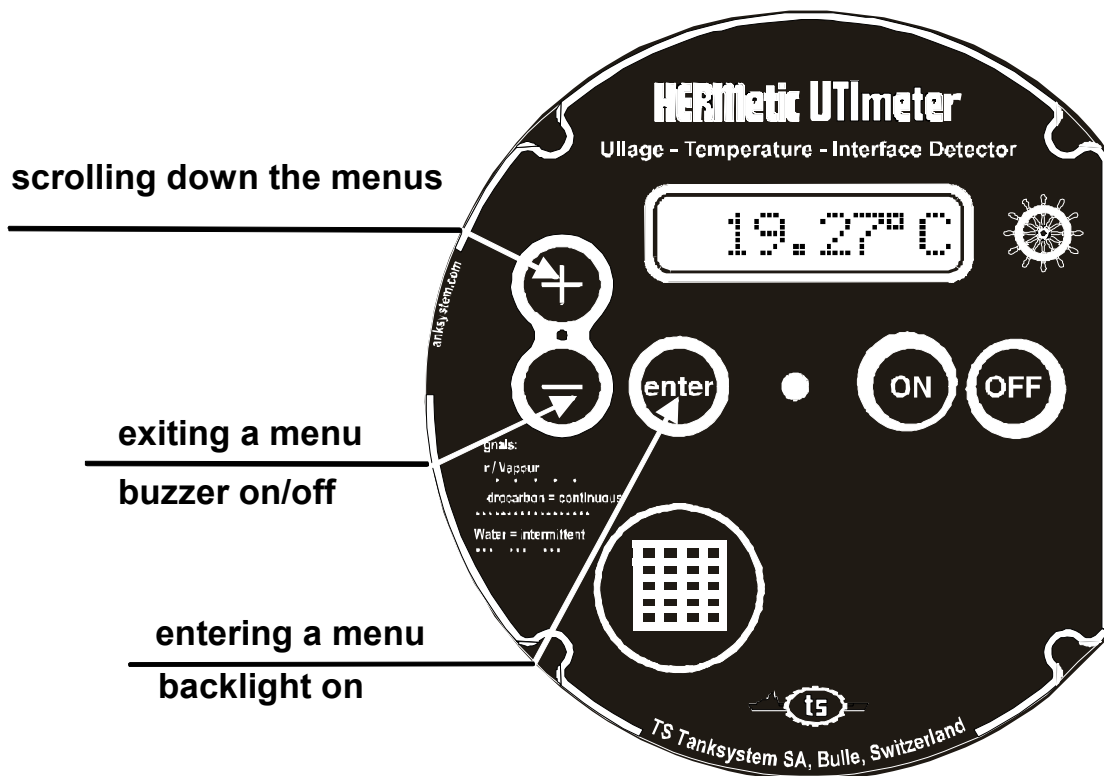

Figure 7-1

## 7.2 Selecting the language

English, German or French languages can be selected by following the sequences described in Figure 7-2.

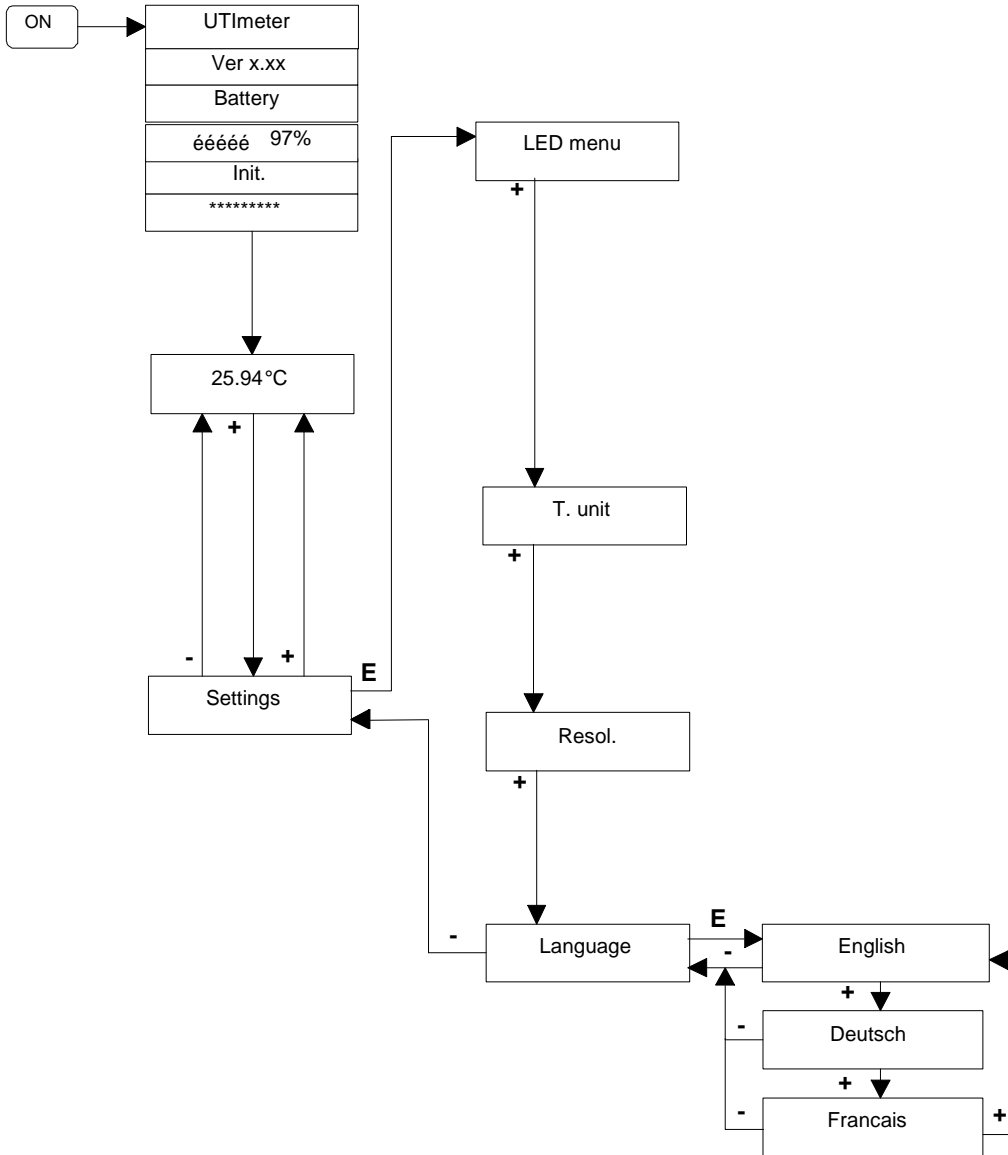

Figure 7-2

- Switch on the equipment,
- Wait until the temperature is displayed,
- Press on "+", to enter the settings menu,
- Press on "enter", "LED menu" is displayed,
- Press on "+"; "T. unit" is displayed,
- Press on "+", "Resol." is displayed,
- Press on "+", "Language." is displayed,
- Press on "enter",
- Select the language by pressing on "+" one or more times, the display shows the language selected,
- Press "-" two times to come back in measurement mode.

The new setting is stored in the permanent memory.

### 7.3 Selecting the temperature scale

The temperature can be displayed either in Celsius or Farenheit degrees. Refer to Figure 7-3.

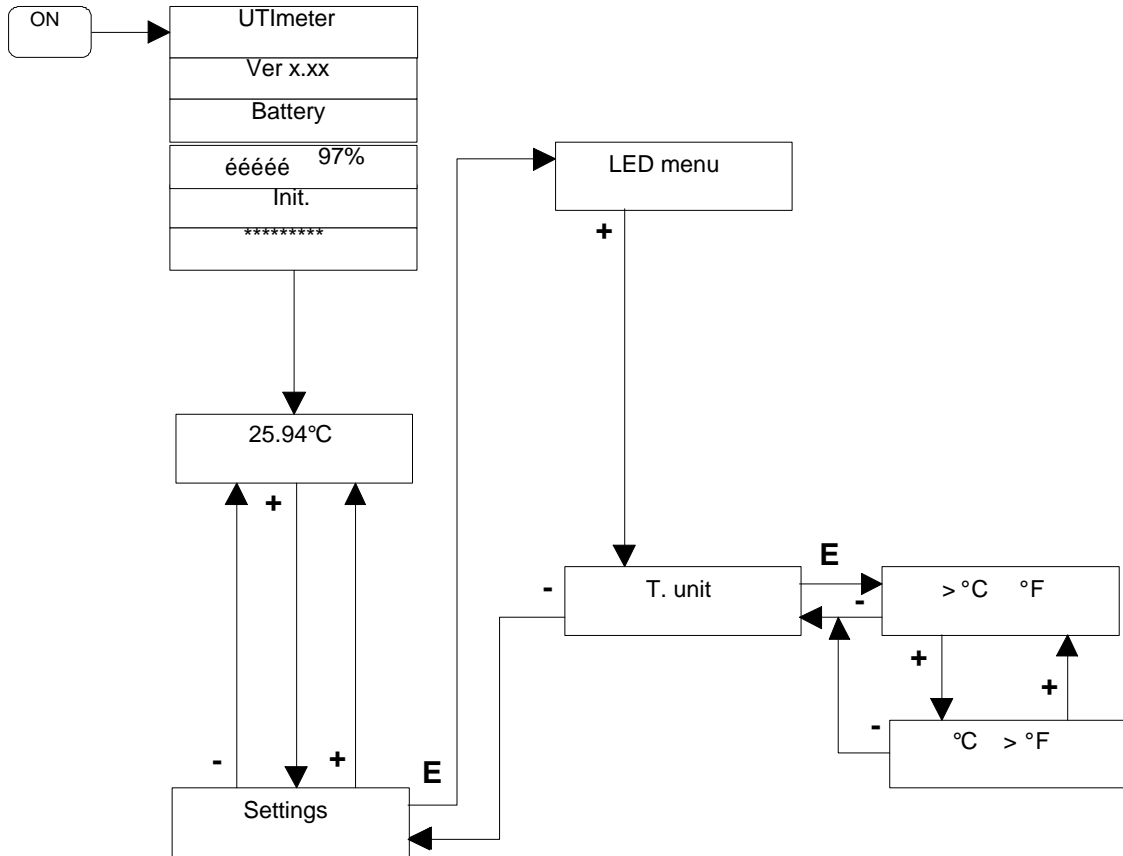

Figure 7-3

- Switch on the equipment,
- Wait until the temperature is displayed,
- Press on "+", to enter the settings menu,
- Press on "enter", "LED menu" is displayed,
- Press on "+"; "T. unit" is displayed,
- Press on "enter",
- Select the scale by pressing on "+" one or more times, the pointer shows the scale selected,
- Press "-" two times to come back in measurement mode.

The new setting is stored in the permanent memory.

## 7.4 Selecting the temperature resolution

The temperature reading can be given with 1 or 2 digits after the dot. Select the appropriate resolution as shown on Figure 7-4.

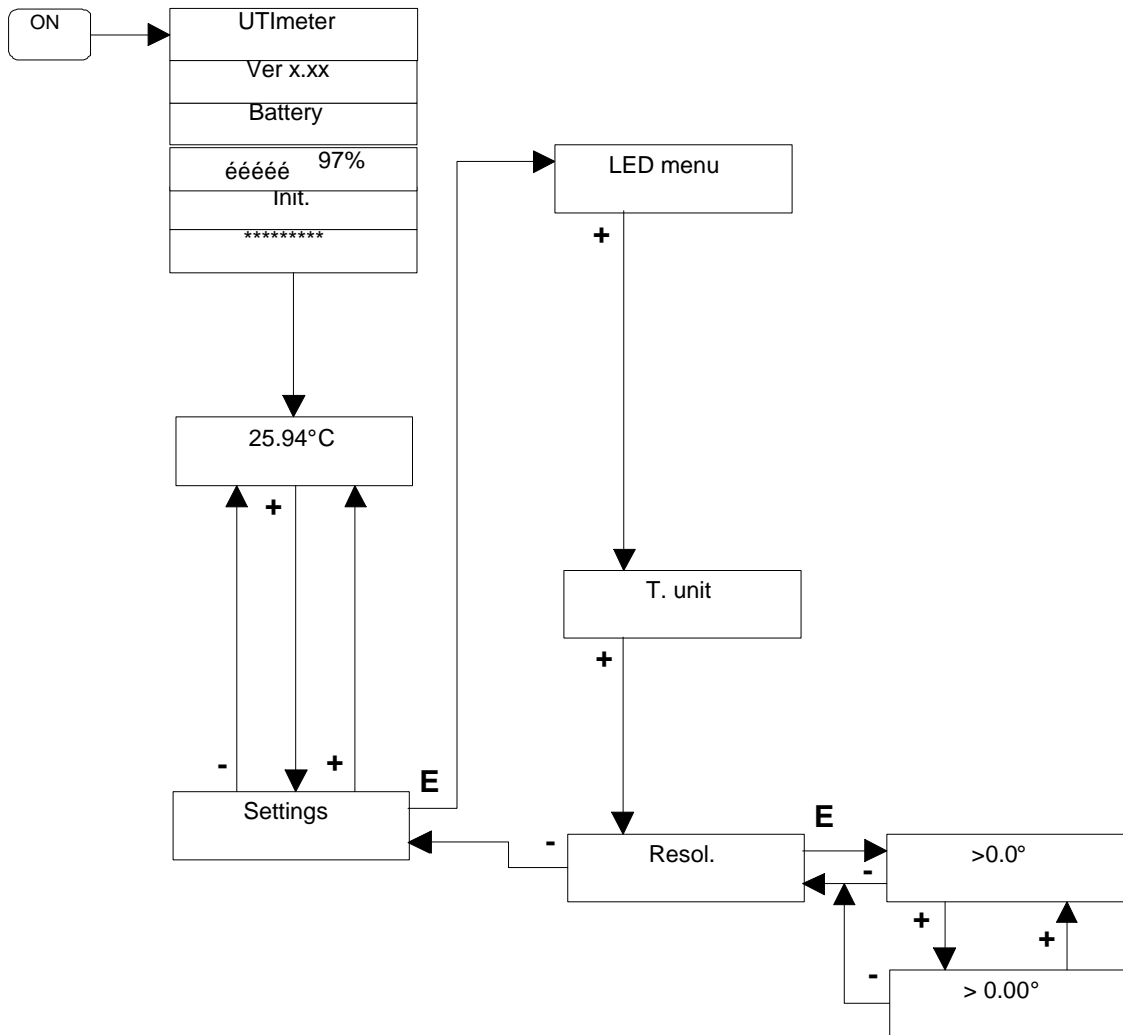

Figure 7-4

- Switch on the equipment,
- Wait until the temperature is displayed,
- Press on "+" to enter the settings menu,
- Press on "enter", "LED menu" is displayed,
- Press on "+"; "T. unit" is displayed,
- Press on "+", "Resol." is displayed,
- Press on "enter",
- Select the resolution by pressing on "+" one or more times, the pointer shows the resolution selected,
- Press "-" two times to come back in measurement mode.

The new setting is stored in the permanent memory.

## 7.5 Activating the LED

Refer to Figure 7-5.

The LED can be activated on 2 modes:

- one is temporary, it is automatically erased when the unit is switched off, in order to save the battery life;
- the other is permanent, it will stay even is the unit is switched off.

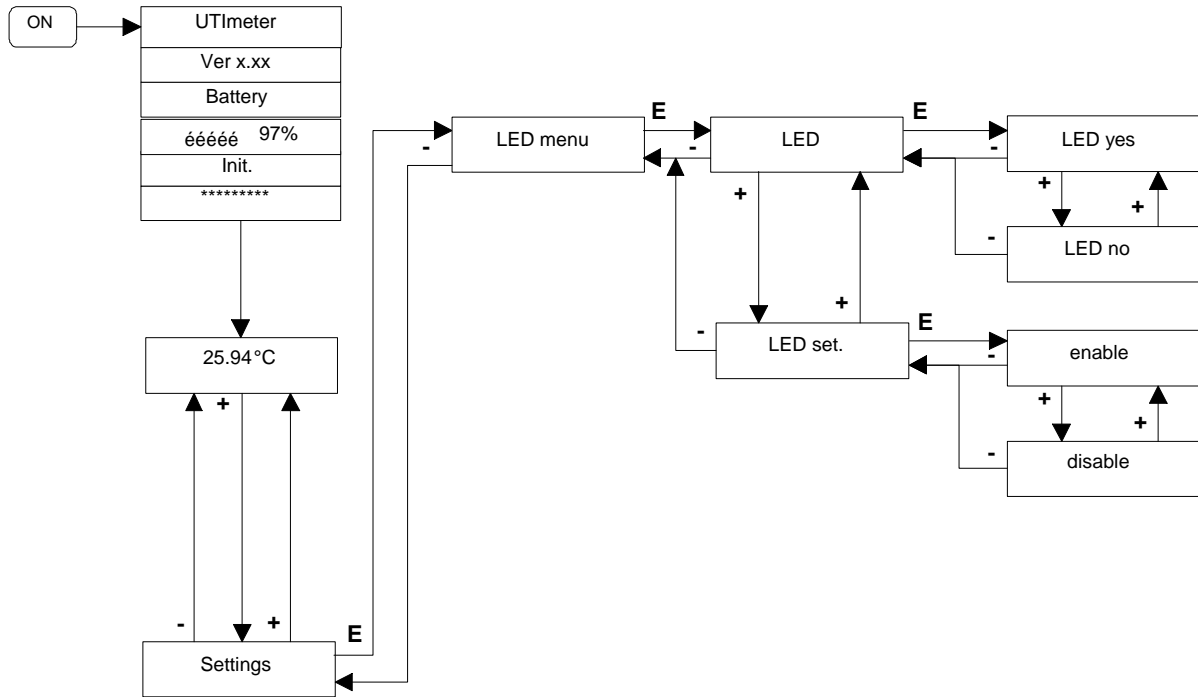

Figure 7-5

### 7.5.1 Temporary setting of the LED

- Switch on the equipment,
- Wait until the temperature is displayed,
- Press on "+" to enter the settings menu,
- Press on "enter"; "LED menu" is displayed,
- Press on "enter"; "LED" is displayed,
- Press on "enter", then select by pressing "+" the mode: "LED yes" or "LED no".
- Press "-" two times to come back in measurement mode.

It is always possible to change the status of the LED during gauging, by using the same menu again. If not done before, switching off the unit will automatically light off the LED.

### 7.5.2 Permanent setting of the LED

- Switch on the equipment,
- Wait until the temperature is displayed,
- Press on "+" to enter the settings menu,
- Press on "enter"; "LED menu" is displayed,
- Press on "enter"; "LED" is displayed,
- Press on "+", "LED Set." is displayed,
- Press on "enter",
- "Enable" or "disable" the LED by pressing on "+" one or more times,
- Press "-" two times to come back in measurement mode.

The new setting is stored in the permanent memory.

**Remember that the LED needs an extra power and reduces the battery life accordingly.**

## 7.6 Muting the buzzer

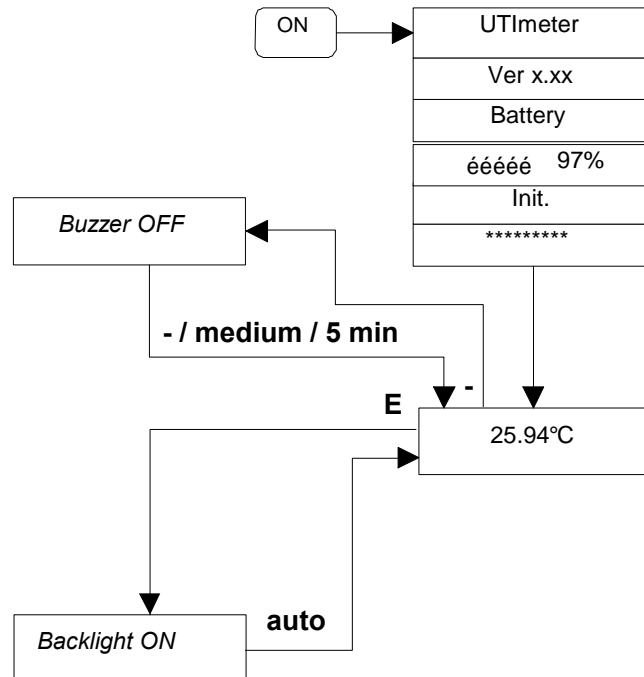

Figure 7-6

When in measurement mode it is possible to mute the buzzer.

- Press on "-",
- Press on "-" again to reset the buzzer.

**IMPORTANT NOTE:** in order to prevent any misuse of the equipment, there is an automatic reactivation of the buzzer each time the medium changes (air to liquid, liquid to water, etc.) or after 5 minutes muting. To keep the buzzer muting, press again on "-".

## 7.7 Backlight

Refer to Figure 7-6.

When in measurement mode press "enter": this switches on the backlight. After around 10 seconds, the light switches off automatically to save the battery life.



## 7.8 Checking the functions before using the instrument

Before installing the HERMetric instrument as described in section 7.1 the following tests have to be carried out to check that the instrument is ready to work.

### 7.8.1 Battery

Refer to section 8.2 "Checking the battery".

### 7.8.2 Reading index

**Otex standard version.** The reading shall be 0 mm when the sensor tip end is 4 mm below the plate level. To adjust it refer to section 8.9.

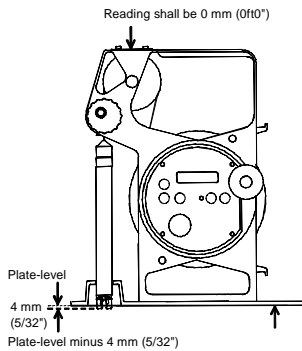
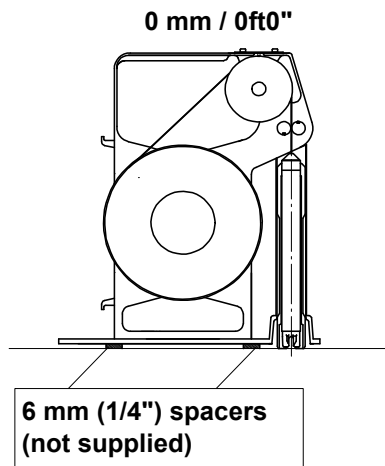

Figure 7-7

**Otex Visc or French plate version.** The reading shall be 0 mm when the sensor tip end is 6 mm below the plate level. To adjust it refer to section 8.9.



### 7.8.3 Temperature

Switch on the unit.  
The buzzer shall beep every 2 sec.  
When the temperature is displayed, check that it shows the surrounding temperature.

### 7.8.4 Ullage

Switch on the unit.  
The buzzer shall beep every 2 sec.  
Check the ullage in a glass of water.  
Check the ullage by immersing the ultrasonic gap sensor but not the electrodes (position A); The buzzer shall beep continuously.

### 7.8.5 Interface

Switch on the unit.  
The buzzer shall beep every 2 sec.  
Check the interface in a glass of water.  
Check the interface by immersing the interface electrodes also (position B). The buzzer shall beep intermittently.

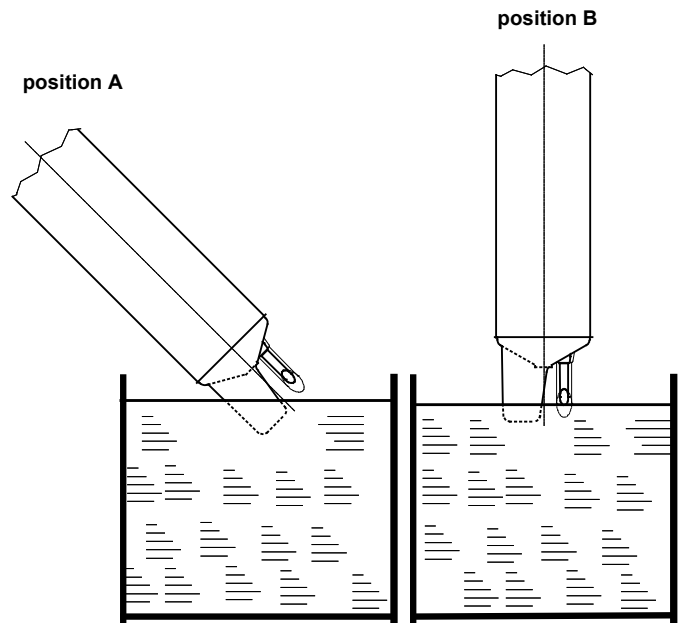

Figure 7-8

## 7.9 Installation of the instrument

- Before starting please read carefully chapter "Recommendation for safe use" and follow your company's safety instructions.
- Install the HERMetic equipment on the edge of the tank opening.
- **Connect the instrument to a grounded conductive part of the tank with the grounding cable.**
- **Attention is drawn to the fact that paint coatings and oxidised parts are insulating.**

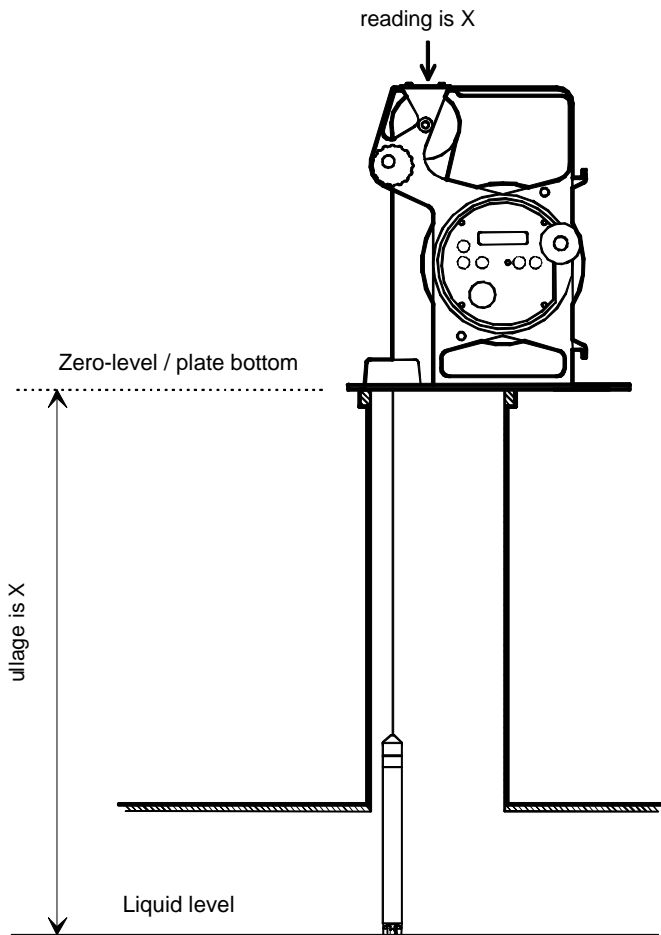

Figure 7-9

## 7.10 Ullage / interface measurement

- Install the HERMetic equipment as per 7.9 "Installation of the instrument".
- Switch on the equipment: a control beep is audible every 2 seconds.
- Check that the tape cleaner is on the "DOWN" position. Disengage the knob of the crank handle and lower the sensing probe into the tank by turning the reel. Make sure that the tape does not rub on any sharp edge when lowering as its insulation could be damaged.
- As soon as the sensor comes in contact with the petroleum product the control beep will change for a continuous beep. Raise the sensing probe again until the continuous beep stops and lower the sensing probe again slowly until the continuous beep is heard again. Now the ullage level can be read against the ullage reference. If the zero-ullage reference does not correspond to the reading index of the instrument, a correction has to be made accordingly.
- Lower the sensing probe further until the sensor touches the oil-water interface. As soon as the sensor comes in contact with water the continuous beep will change for an intermittent beep. The difference between the ullage reading and the interface reading represents the thickness of the product layer.
- When the measurements are completed, switch off the unit, turn the tape cleaner on "UP" position and wind up the tape until the sensing probe is in the storage tube. The reading on the tape shall be zero.

### 7.11 Reference height / innage measurement

For manual detection of the dip/datum plate it is advised to use the HERMetric UTImeter Visc version. If the unit is fitted with the additional load \*Visc Version\* (see Figure 7-10) then reference height / innage measurement are possible.

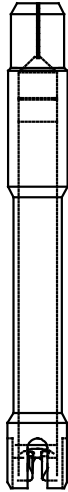

Figure 7-10

- Install the HERMetric equipment as per 7.9 "Installation of the instrument".
- Check that the tape cleaner is on the "DOWN" position. Disengage the knob of the crank handle and lower the sensing probe into the tank by turning the reel. Make sure that the tape does not rub on any sharp edge when lowering as its insulation could be damaged.
- When the sensing probe comes in contact with the dip/datum plate record the distance shown on the reading index. See Figure 7-11. The exact distance from the plate to the reading index is (reading + 6 mm) or (reading +1/4" approx.) which is the reference height providing the reading index level has been adjusted to the zero ullage level of the tank. If the tank zero ullage is levelled above or below the reading index, an additional correction shall apply.
- Turn the tape cleaner on "UP" position.
- Switch on the unit and raise up the sensing probe until checking the oil/water interface if any (see details in section 7.10 "Ullage / interface measurement"). To get a better accuracy of the interface level, release the tape cleaner on the "DOWN" position during the final checking. Calculate the free water height

by subtracting the index reading to the reference height.

- Reengage the tape cleaner on the "UP" position and raise up the sensing probe until checking the ullage (see details in section 7.10 "Ullage / interface measurement"). Release the tape cleaner for final checking of the ullage. Calculate the innage by subtracting the index reading and the free water height to the reference height determined before.
- When the measurements are completed, switch off the unit, engage the tape cleaner on the "UP" position and wind up the tape until the sensing probe is parked. The reading on the tape shall be zero.

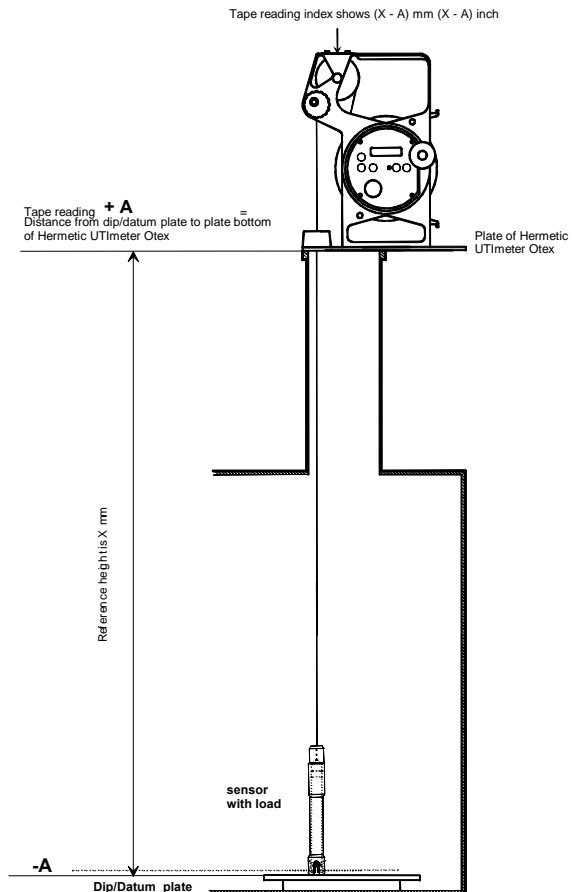

Figure 7-11

UTImeter Version	Offset correction A
Otex Visc	6 mm
Otex French plate	6 mm

## 7.12 Temperature measurement

- Install the HERMetric equipment as per 7.9 "Installation of the instrument".
- Check that the tape cleaner is on "DOWN" position. Disengage the knob of the crank handle and lower the sensing probe to the **deepest** reading desired. Make sure that the tape does not rub on any sharp edge when lowering; its insulation might be damaged.
- The position of temperature sensor coincides with zero of tape, so the tape index reading shows directly level at which temperature is measured
- Switch on the unit: a control beep is audible every 2 seconds. The buzzer can be deactivated by pressing on the "-" key.
- When the desired temperature ullage level is reached, joggle the sensing probe approximately 300 mm (1 foot) above and below the desired measurement level until the displayed temperature reading settles. For heavy crude oils which have a low thermal conductivity and a viscous nature, the joggling procedure is a necessity to assure an accurate temperature reading in a minimum amount of time.
- When temperature has settled, record it.
- Engage the tape cleaner on "UP" position. Raise the probe to the next ullage level to be measured and repeat the procedure a.m. To joggle the sensing probe the tape cleaner must be on the "DOWN" position.
- When the measurements are completed, switch off the unit, engage the tape cleaner on "UP" position and wind up the tape until the sensing probe is in the storage tube. The reading on the tape shall be zero.

### IMPORTANT NOTE

As mentioned in 7.6 "Muting the buzzer" it is easy to mute the buzzer during the temperature measurement by pressing on "-".

Recall that after 5 minutes have elapsed or each time the probe detects a change of the medium (air, liquid, water), the buzzer will reactivate automatically. To keep it muting, press on "-" again.

## 8. Care and Maintenance

### 8.1 Care

Clean the instrument of any excess of liquid after use.

Make sure that the sensing probe is completely parked after use (reading index shall indicate zero).

Check the tightness of the reading index screws and if necessary adjust the level, refer to section 6.4 "Reading index".

Store the instrument in a dry location.

Check periodically (at least every 6 months) the continuity of grounding by measuring the electrical resistance between the tape adaptor (or the sensing probe tube) and the grounding cable. Resistance should not exceed 10  $\Omega$ .

Periodically clean carefully the sensor probe, the tape and the mechanical parts with an appropriate solvent.

Check periodically the condition of the tape cleaner.

With such conductive liquids which form salts when drying, wash the sensing probe with water or alcohol and brush it very gently with a soft brush to prevent a water detection error due to a short-circuit between the electrode and the tube.

## 8.2 Checking the battery

Please note that in case you have to change the battery, it must be done only in a safe area. Refer to section 8.3 "Battery replacement".

### 8.2.1 Before starting gauging

Switch on the unit. The buzzer tones every 2 seconds if the battery is not too low.

The following sequences are displayed as per Figure 8-1, the 4<sup>th</sup> sequence shows the remaining power of the battery in percentage and as a bar-graph.

If the power left is less than 50% we recommend to have a spare battery ready for exchange. See also 8.3 "Battery replacement".

If the power left is less than 20% the message is blinking to advise that the power may not be enough to carry out all the work.

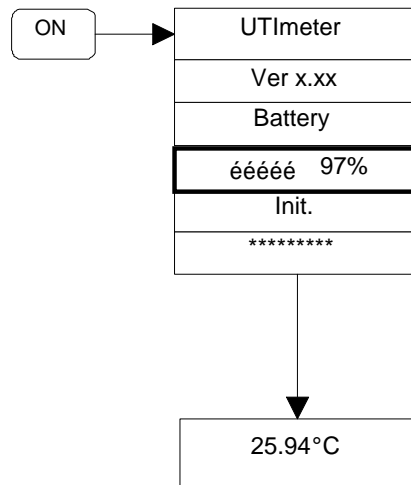

Figure 8-1

If the battery is too low, the unit will stop on the message "battery" as shown on Figure 8-2 and the buzzer tones continuously. Change the battery as per 8.3 "Battery replacement".

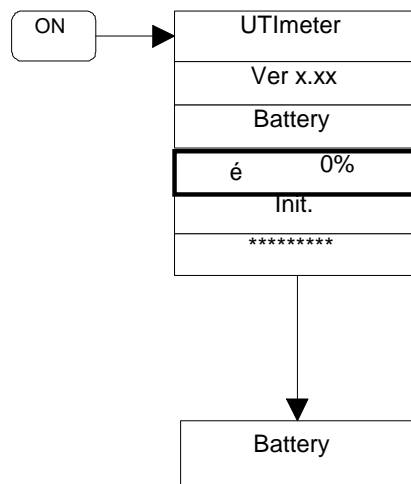

Figure 8-2

If it is not possible to switch on the unit, the battery is out or work. Change the battery first, as per 8.3 "Battery replacement".

### 8.2.2 During gauging

When the unit is already switched on and working, it is always possible to see what power is left with the battery by entering the settings menu:

- Press on "+" to enter the settings menu,
- Press on "enter", "LED menu" is displayed,
- Press on "+"; "T. unit" is displayed,
- Press on "+", "Resol." is displayed,
- Press on "+", "Language" is displayed,
- Press on "+", "Battery" is displayed,
- Press on "enter",
- The remaining battery power is displayed in percentage and as a bar-graph; pressing "+" again allows to see the tension of the battery (B); the last information (A) is internal.
- Press "-" two times to come back in measurement mode.

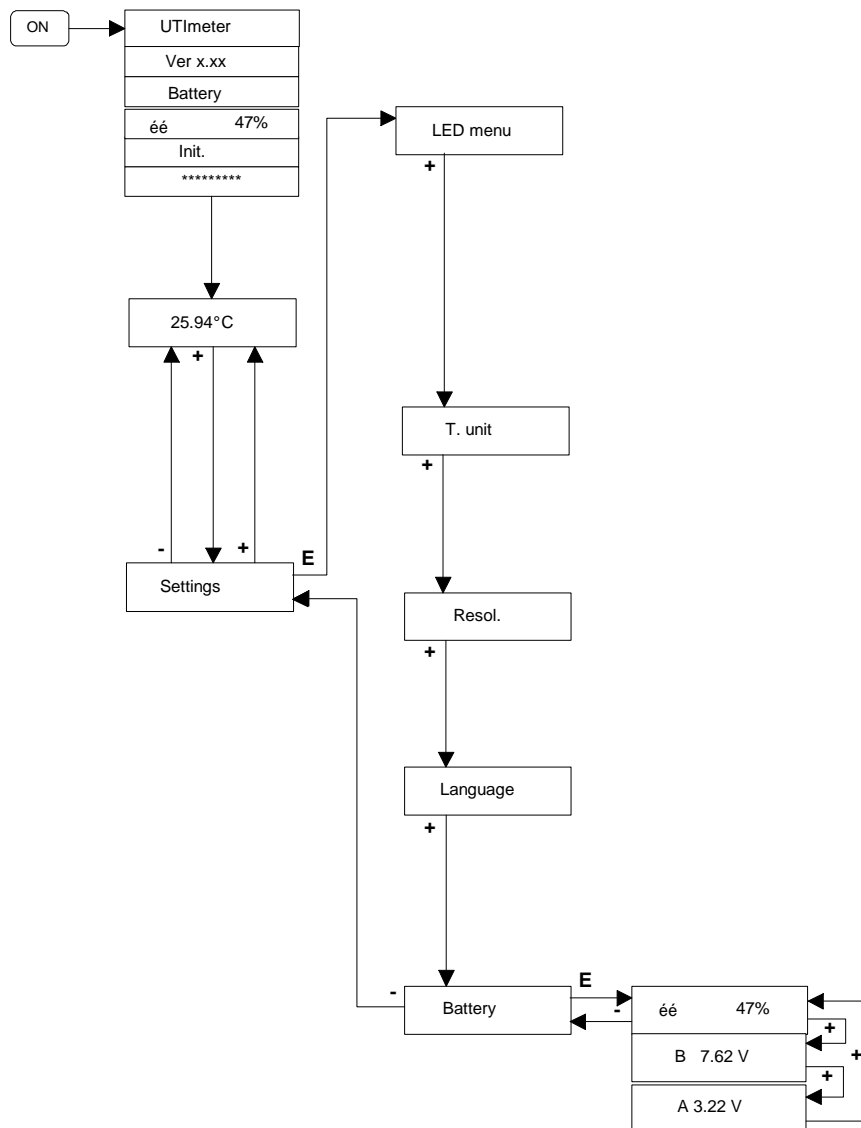

Figure 8-3

### 8.3 **Battery replacement**

**Warning :** *change the battery only in a non hazardous area.*

- Unscrew the 2 screws of the battery holder using the 2,5 mm Hex Allen key which is located on the carrying case. See Figure 8-4.
- Pull it gently out.
- Change the battery (one-way only device). See Figure 8-4.
- Push the battery holder back in its housing (one-way only).
- Tighten the 2 screws.

**Only one battery is approved:**

**Duracell / Procell MN1604**

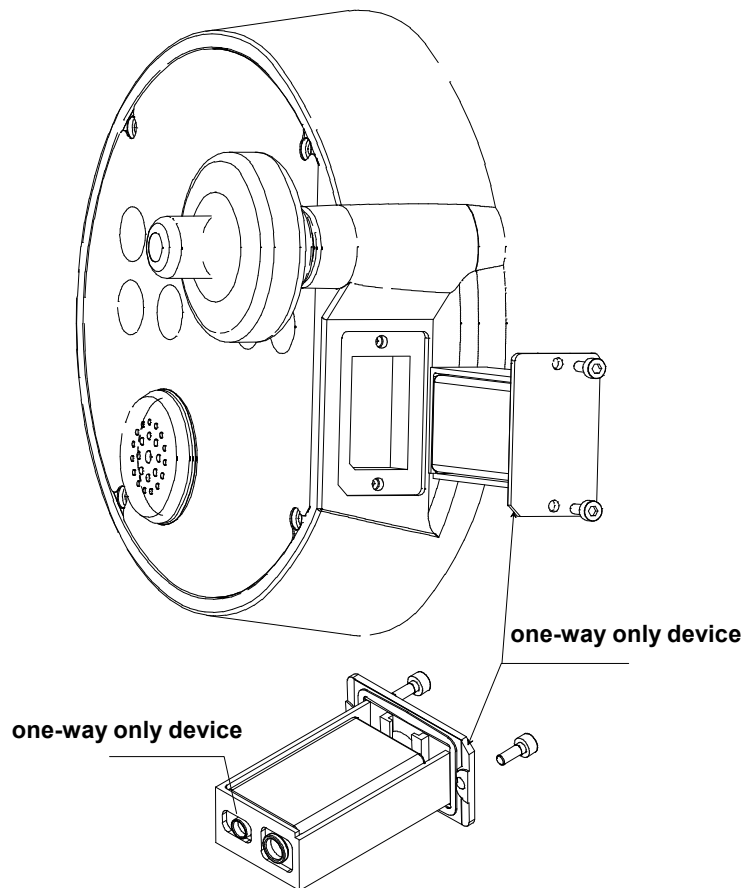

**Figure 8-4**



## 8.4 Tape replacement

### THE REPLACEMENT OF THE TAPE DOES NOT REQUIRE TO RE-CALIBRATE THE TEMPERATURE.

Follow the different sequences as described below. The Figure 11-1 : general assembly HERMeTic UTImeter Otex standard version, list of the main spare parts can also help.

#### 8.4.1 Disconnecting the tape from the sensor

Follow the instructions of section 8.5 "Sensing probe replacement".

#### 8.4.2 Disconnecting the tape from the electronic box

- Unscrew with the 2.5 Allen key the 2 screws (A) of the battery holder and pull it out as shown on Figure 8-5.
- Unscrew with the 2.5 Allen key the 4 screws (B) of the display unit and pull it gently out as shown on Figure 8-5.

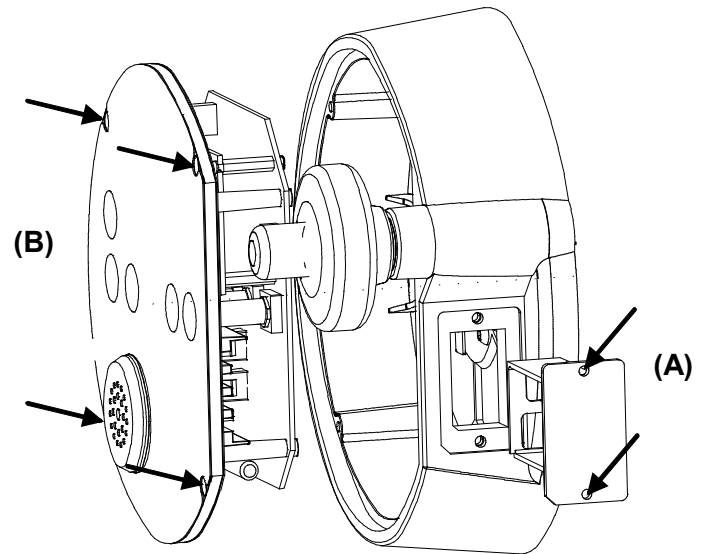

Figure 8-5

- Disconnect the connecting plug (C) as shown on Figure 8-6 and remove the display unit.
- Unscrew with the 2.5 Allen key the tape holder (G) by removing the 2 screws (F & I) and the grounding cable (D) as shown on Figure 8-6. Do not loose the 2 remaining screws that secure the reel axle.
- For the mounting procedure, secure screws (F & I) with glue

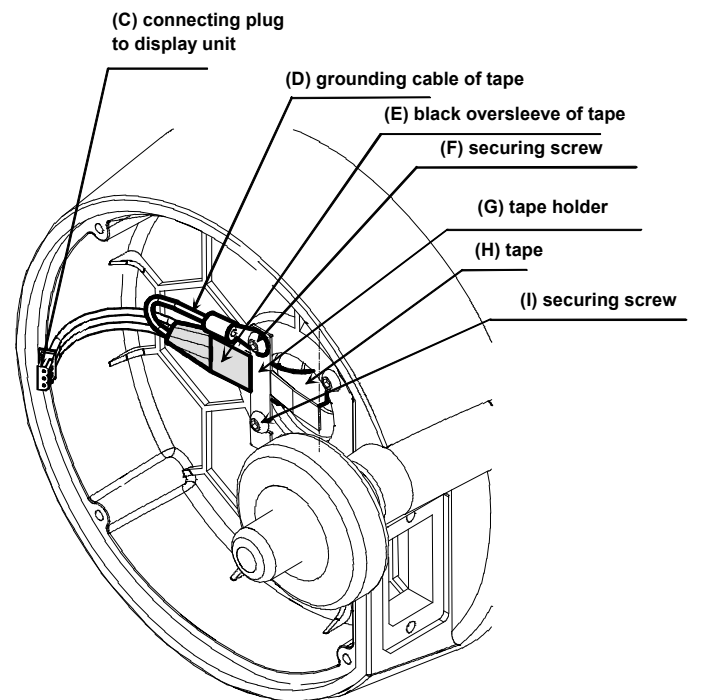

Figure 8-6

### 8.4.3 Disconnecting the tape from the reel axle

- Remove the external reel flange (3 screws to unscrew with the 2.5 Allen key).
- Unscrew with the 2.5 Allen key the 4 screws (K) of the washer holder, as shown on Figure 8-7.
- Remove the tape from the reel axle.

### 8.4.4 Removing the tape from the frame

- Turn the tape cleaner in position "DOWN" to free the tape.
- Pull the tape gently out of the tape cleaner.
- Unscrew and remove the pulley. Please note that the pulley is not symmetrical, one diameter is 1mm bigger than the other.
- Slacken the tape a few turns from the reel axle.
- Remove the tape from the housing.

### 8.4.5 Mounting the new tape

- Install the new tape on the reel axle.
- Leave approximately 20 cm of tape free at the core.
- Make a loop (M) and a S-shape (L) with the tape as shown on Figure 8-7.
- Pass the tape end through the axle core.
- Secure the gaskets and the washers mounted on the tape in the axle core with the washer holder and its 4 screws (K) as shown on Figure 8-7. Do not tighten the 4 screws (K).
- On the electronic box side, adjust the black oversleeve just to the edge of the tape holder (pull the tape gently from the other side) and tighten the tape end as shown on Figure 8-6.
- Tighten the 4 screws (K).
- Follow in the reverse order the instructions of sub-section 8.4.2 to re-install the electronic box. Do not forget to secure the screws (F & I) with glue.
- If necessary, readjust the loop (M) and the S-shape (L) of the tape at the core of the reel axle.
- Follow the instructions of sub-section 8.4.4 in the reverse order to pass the tape through the tape cleaner.
- Put back and secure the pulley. Note that the pulley is not symmetrical: the special groove shall stay opposite of the frame (see Figure 8-8).
- Put back the reel flange and its 3 securing screws.
- Check the good adjustment of the reading index as described in section .

- Follow the instructions of section 8.5 "Sensing probe replacement" to re-install the sensor on the tape.
- Carry out the functional tests as per 7.8 "Checking the functions before using the instrument".
- If there is any problem, refer to section 9 "Trouble shooting".

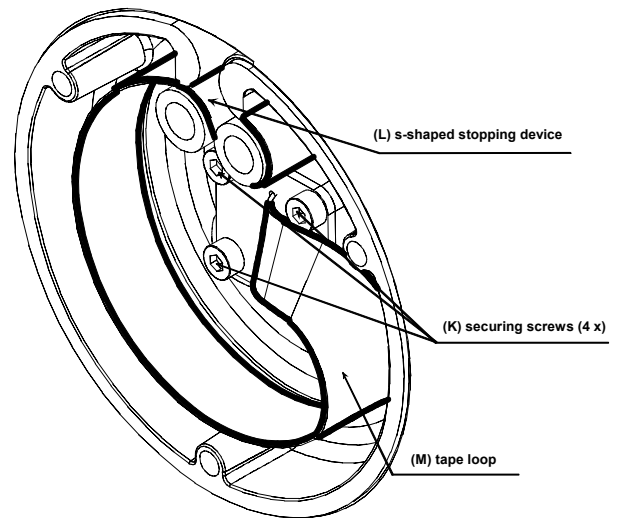

Figure 8-7

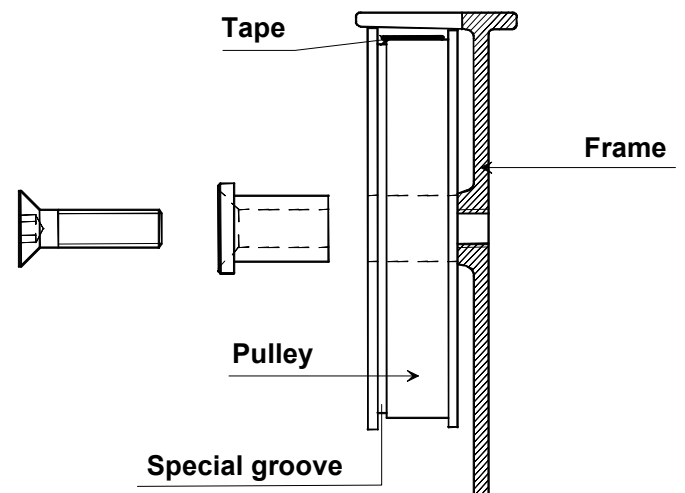

Figure 8-8

## 8.5 Sensing probe replacement

**THE REPLACEMENT OF THE SENSING PROBE DOES NOT REQUIRE TO RE-CALIBRATE THE TEMPERATURE NOR THE ULLAGE / INTERFACE.**

### 8.5.1 Disconnecting the old sensing probe

- Unscrew the securing screw with the 1.5 mm Hex Allen key.
- Pull carefully the adaptor out of the sensing probe tube by turning it slightly left and right. Make sure that the O-ring is not damaged when it passes the hole of the sensing probe tube.
- Disconnect the plug by pulling it gently out of the tube.

### 8.5.2 Connecting the new sensing probe

- Refer to Figure 8-9.
- Insert the 1.5 Allen key gently in the free hole in the middle of the tape plug.
- With one hand keep the sensing probe and the tape adaptor as shown on Figure 8-9.
- With the other hand drive the plug into the new sensor tube with the 1.5 Allen key to connect it to the sensing probe socket. Note this is a one way only plug. The wires shall be on the opposite side of the electronic circuit print as shown on Figure 8-9.
- Pull out gently the 1.5 Allen key from the plug while keeping the plug in place with another non sharp tool, for instance the 4 mm Allen key. Check that the plug is fully inserted.
- Switch on the unit and wait a few seconds. If all is OK, the temperature is displayed and the buzzer beeps every 2 seconds. If there is any problem, refer to the section 9 "Trouble shooting".
- Put some light grease on the O-ring.
- Push gently the adaptor into the sensing probe tube. Mind not to damage the O-ring when it passes the screw hole.
- Screw the securing screw back with the 1.5 mm Hex Allen key.

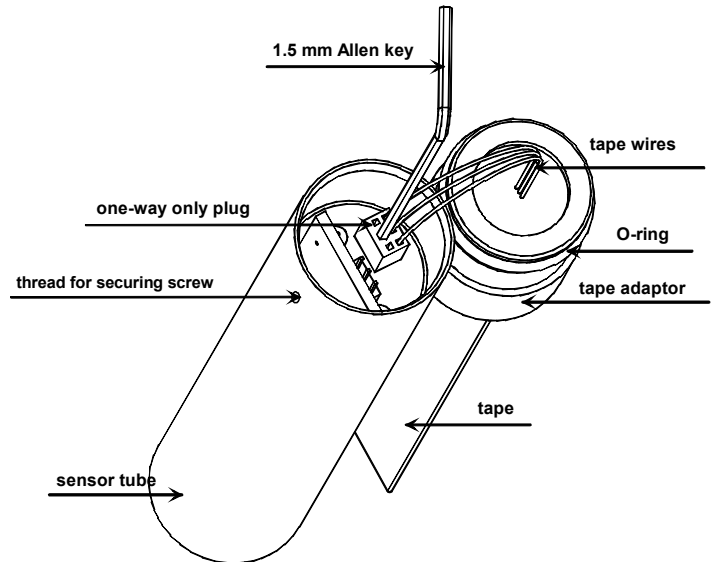

Figure 8-9

## 8.6 Tape wipers replacement

The 2 tape wipers can be easily replaced:

- Check that the tape cleaner is on "DOWN" position.
- The tape wipers are inserted in holders grooves. Remove the old ones and insert the new ones.
- Check that the tape cleaner is working properly.

**Note:** we recommend to change always both wipers.

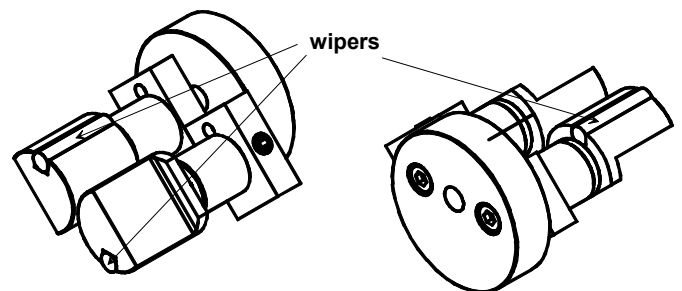

Figure 8-10

## 8.7 Display unit replacement

### THE REPLACEMENT OF THE DISPLAY UNIT DOES NOT REQUIRE TO RE-CALIBRATE THE TEMPERATURE.

#### 8.7.1 Disconnecting the old display unit

- Unscrew with the 2.5 Allen key the 2 screws (A) of the battery holder and pull it out as shown on Figure 8-11.
- Unscrew with the 2.5 Allen key the 4 screws (B) of the display unit and pull it gently out of the electronic box, as shown on Figure 8-11.
- Disconnect the tape plug, item (C) shown on Figure 8-6.

#### 8.7.2 Connecting the new display unit

- Connect the tape plug to the new display unit.
- Put back the new display unit in the electronic box; tighten the 4 screws (B) of Figure 8-11.
- Reinstall the battery holder with the 2 screws (A) of Figure 8-11.
- Check that the unit is working properly, as described in 7.8.

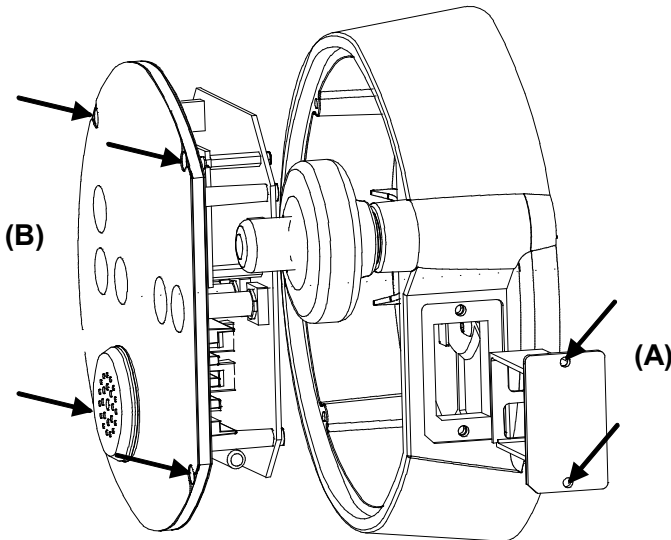

Figure 8-11

## 8.8 Verification and certification of tapes

The tape has to be periodically inspected for breaks, kinks, wear and illegible numbers.

As the tape is a cable it might be necessary to check its electrical conformity. Refer to section 9.8. It is necessary also to check it for accuracy regularly according to current National or International Standards, as API "Manual of Petroleum - Measurement Standards - Chapter 3 - Tank Gauging - Section 1A - Standard practice for the manual gauging of petroleum products in stationary tanks" or IP "Petroleum Measurement Manual - Part III - Manual Tank Gauging - Section 1 - Non-Electrical Methods" or relevant ISO standards.

In such a case it is important to remember that the bottom of the sensing probe is 4 mm lower than the zero of the tape, thus to assure that the electrical zero coincide with the tape zero.

It is also important to remember that the nominal tension at which the tape was produced is marked on each beginning of tape and is normally 6 N (1,3 lb). If tensioned at 44,5 N (10 lb) as per API this will result in a additional elongation up to 3.7 mm over 30 meters.

This periodical verification can be done at the factory or in a Service Station.

### 8.9 Verification and adjustment of the reading index

#### UTImeter Otex Standard Version

To verify or to adjust the reading index, in particular after having renewed a tape, apply the following instruction:

- prepare 2 spacers 4 mm thick (5/32") and a flat surface;
- put the tape cleaner on "DOWN" position;
- keep the equipment standing vertically on the 2 spacers; make sure that the surface is flat between the 2 spacers and that the spacers are placed on the flat part of the Otex plate;
- gently lower the tape until the sensor gets in contact with the surface(Figure 8-12);
- the reading on the tape shall be exactly 0 mm;
- Loose the 2 screws and adjust the index to this value of 0 mm (0ft0"). Tighten the 2 screws.

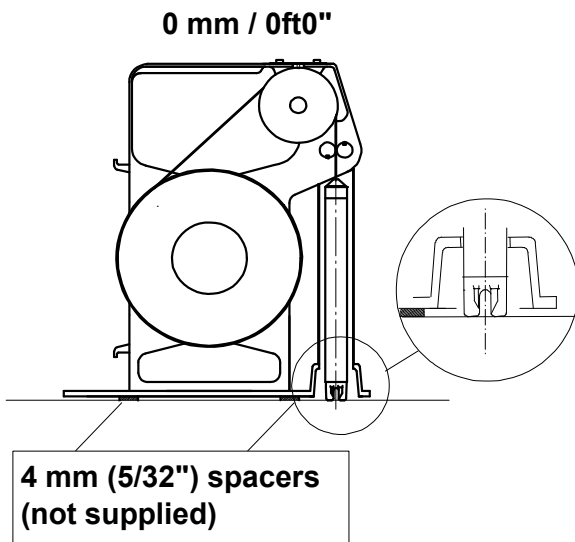

Figure 8-12

#### UTImeter Otex Visc Version

To verify or to adjust the reading index, in particular after having renewed a tape, apply the following instruction:

- prepare 2 spacers 6 mm thick (1/4") and a flat surface;
- put the tape cleaner on "DOWN" position;
- keep the equipment standing vertically on the 2 spacers; make sure that the surface is flat between the 2 spacers and that the spacers are placed on the flat part of the Otex plate;
- gently lower the tape until the sensor gets in contact with the surface(Figure 8-13);
- the reading on the tape shall be exactly 0 mm;

- Loose the 2 screws and adjust the index to this value of 0 mm (0ft0"). Tighten the 2 screws.

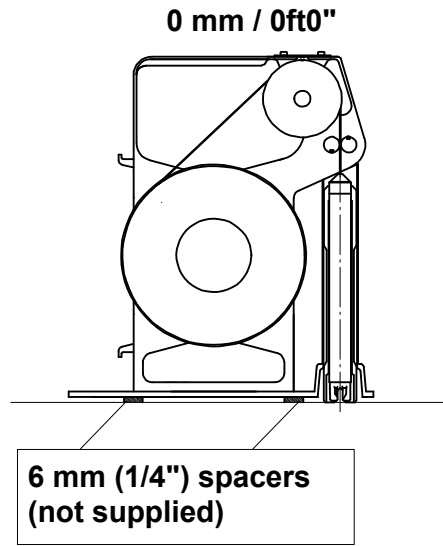

Figure 8-13

UTImeter Version	Offset correction
Otex Standard	4 mm
Otex Visc	6 mm
Otex French plate	50+6 mm

### 8.10 Temperature verification

The temperature calibration curve is stored in the sensor memory and cannot be modified. The calibration is set once at the factory and do not require subsequent adjustment.

Nevertheless it is recommended to check the temperature accuracy once a year. A one point check is enough to qualify the sensor.

#### 8.10.1 Equipment required

- A Dewar flask or any vacuum flask, approximately 8 cm in diameter and 36 cm deep.
- Ice, preferably made from distilled water.
- Water, preferably distilled and precooled.

#### 8.10.2 Preparing the Ice Point bath

- (1) Shave or crush the ice into small pieces, avoiding direct contact with the hands or any unclean object. The pieces shall be no more than 5 mm.
- (2) Fill the Dewar flask with the crushed ice and add sufficient water to form a slush, just filling the voids between ice particles but not enough to float the ice.

- (3) Insert the sensor, packing the ice gently about it.
- (4) Let it stand for half an hour to permit the sensor temperature, the ice particles and the water to equilibrate.
- (5) As the ice melts it will be necessary to drain off some water and add more crushed ice. Gently stir the ice with the sensor periodically to assist equilibration.

**IMPORTANT NOTE:** Attention to detail during the preparation of the Ice Point bath is critical to the accuracy and quality of the offset verification.

### 8.10.3 Checking the UTImeter

- (6) After 30 minutes have elapsed, gently stir the bath with the sensor again to ensure complete equilibration of temperature.
- (7) Switch on the UTImeter.
- (8) Observe the reading. It should be  $\pm 0.10$  °C ( $\pm 0.20$  °F) The temperature must be stable, i.e. within  $\pm 0.04$  °C ( $\pm 0.07$  °F).
- (9) If it is not OK, refer to section 9 "Trouble shooting".

## 8.11 Ullage/Interface verification

The sensitivity of the instrument in ullage / interface cannot be adjusted. Both ullage and interface levels are set at the factory.

### Checking ullage and interface level detection

The test liquid should be the one to be gauged. Fill in a container with appropriate liquid.

Switch on the unit. The buzzer shall beep every 2 sec.

If the liquid is conductive (alcohol, water, ...)

- Check the **ullage** by immersing the ultrasonic gap sensor but not the electrodes (position A); The buzzer shall beep continuously.
- Check the **interface** by immersing the interface electrodes (position B). The buzzer shall beep intermittently.

If the liquid is non conductive (gasoline, oil, ...)

- Check the **ullage** by immersing the sensor (position B); The buzzer shall beep continuously.
- Check the interface by immersing the sensor (position B) in water. The buzzer shall beep intermittently.

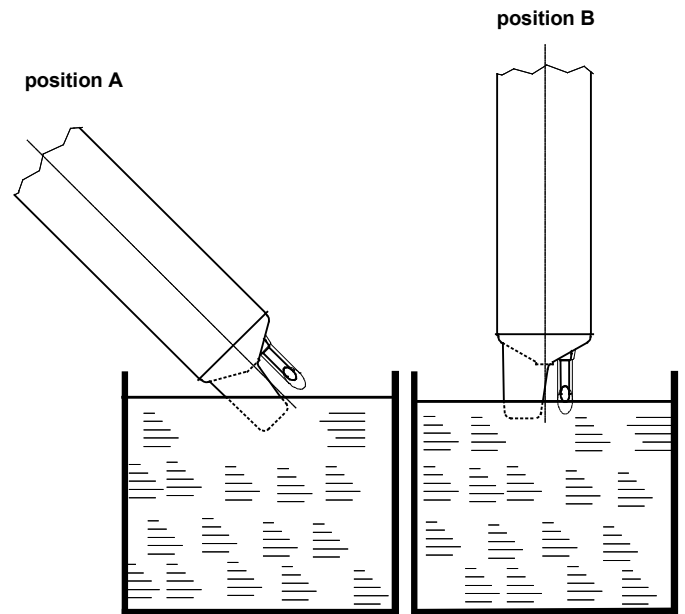

Figure 8-14

## 9. Trouble shooting

### 9.1 Safety warning

As this equipment is designed and approved for use in an explosive area (intrinsic safe equipment), only authorized service stations and the factory are allowed to repair electronic circuits.

However the customer can exchange parts and modules if the following points are observed :

1. Never open the instrument nor carry out any repair or trouble shooting in an hazardous area.
2. Use only original spare parts.
3. Work shall be done only by maintenance personnel who has an experience with intrinsically safe equipment.

The design of the equipment is modular, i.e. in case of breakdown the customer can find out which modules have to be replaced. The instrument consists of the following modules:

- Mechanical parts
- Sensing probe
- Tape assembly
- Display unit / electronic box
- Tape cleaner

The following sections should allow to identify the defective module and to replace it.

### 9.2 Power supply troubles

Symptom	Origin	Action	Section
The unit does not switch on	Battery too low	Change the battery	8.3
	Corrosion of terminals (battery side)	Clean the battery terminals	---
	Corrosion of terminals (display unit side)	Clean the display unit terminals	---
	Switch defective	Change the display unit	8.7
The unit switches on but stops on the message "battery"; the buzzer tones continuously	Battery too low	Change the battery	8.3

### 9.3 Transmission troubles

Symptom	Origin	Action	Section
"No Msg " is displayed	Sensor out of work or	Renew the sensor	8.5
	Tape out of work	Renew the tape	8.4
"Invalid" is displayed	Sensor out of work	Renew the sensor	8.5
"Unknown" is displayed	Sensor out of work	Renew the sensor	8.5

## 9.4 Ullage and/or Interface troubles

Symptom	Origin	Action	Section
The buzzer does not beep when the unit is switched on	Buzzer switched off or	Press on "-" to reactivate it	7.6
	Key-pad defective or	Pressing on "+" has no action Change the display unit	8.7
	Buzzer defective	Press on "+": "Settings" is displayed Change the display unit	8.7
The buzzer tones continuously when the sensing probe is in air or liquid or water	Battery too low	Change the battery	8.3
The buzzer gives the water signal whatever liquid is gauged	Sensing head contaminated by conductive residues	Wash, clean and brush (soft brush) the sensing head or change the sensor	--- 8.5
The buzzer gives the oil signal in water	Sensing head contaminated by non conductive residues	Wash, clean and brush (soft brush) the sensing head or change the sensor	--- 8.5

## 9.5 Temperature troubles

Symptom	Origin	Action	Section
"> 90°C" or "> 194°F" is displayed	Temperature too high	The temperature range shall be < 90°C / 194 °F	---
"< -40°C" or "< -40°F" is displayed	Temperature too low	The temperature range shall be > -40 °C/F	---
Temperature does not stabilise	Heated viscous liquid (such as heavy crude oils)	Check the stability in cold and hot water; if it is OK the problem is with the gauged liquid and not with the probe	---
	Contaminated sensing probe	Clean the temperature electrode; remove any residues or sludge; check the stability in cold and hot water	---

## 9.6 Visual inspection for damaged or missing parts

General condition: missing parts

Display unit: 5-key control pad, buzzer, front face, LED, screen

Sensing probe: sensors broken, smashed or damaged

Tape: check at least the first 3 m; wires still insulated, no breaks, no kinks, ...

Mechanical parts: check frame, reel flange, axle, wipers of tape cleaner, plate



## 9.7 Coated aluminium parts

PA 11: Rilsan = blue, grey or yellow colour

The coating should be subject to regular and careful inspection. The continued use of the apparatus should not be permitted if inspection reveals that the protective material has become damaged to the extent that the underlying protected metal is visible, until such damage has been satisfactorily repaired.

## 9.8 Electrical check of tape assembly

### ⇒ Test for grounding

- Remove the battery holder as described in section 8.3.
- ⇒ Measure the resistance between the ground (-) terminal (as shown on Figure 9-1) of the electronic circuit and the tube of the sensing probe; the resistance should be less than 10  $\Omega$ . If it is higher, the steel tape might be broken or the connection between the sensing probe circuit and the sensing probe tube might be interrupted.

### ⇒ Test for short-circuit

- Disconnect the tape at both ends: display unit side and sensing probe side (see sections 8.4.1 and 8.4.2).
- Measure the resistance between each conductor red-white, red-black, white-black. This resistance should be infinite as an open circuit. If not, the tape might be defective.

### ⇒ Test for open-circuit (continuity)

- Disconnect the tape at the sensing probe side see 8.4.1).
- Measure the resistance of each conductor of the tape (between red and red, white and white, etc.).
- The resistance should be less than 15  $\Omega$ . If not, the tape might be broken. To replace the tape see section 8.4.

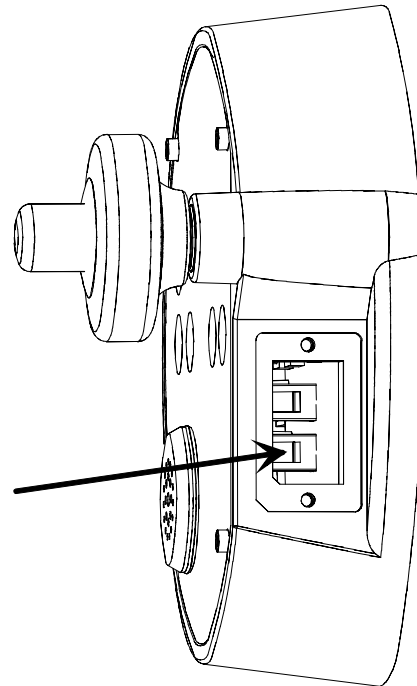

Figure 9-1

## 10. Specifications

### General Specifications

Accuracy of ullage-interface detection	±2 mm (± 0.08" approx.)
Ullage, interface indication	Audible or visible
Tape length	15 m/50 ft, 30 m/100 ft, 35 m/115 ft
Tape graduation	Metric/English
Tape resolution	1 mm / 1/16"
Tape accuracy	±1.5 mm/30 m (±1/16"/100 ft approx.)
Meets ISO 4512 and API MPMS Chap 3.1A requirements	
Diameter of probe (without load)	23 mm (29/32" approx.)
Minimum detectable tank bottom liquid level	4 mm (5/32" approx.)
Accuracy	±0.1°C (0°C to 70°C); ±0.2°F (32°F to 158°F)
meets ISO 4268, API MPMS Chap 7 and IP PMM Part IV requirements	
Ambient temperature range	-20°C to 50 °C (-4°F to 122°F)
Temperature sensor measurement range	-40°C to 90°C (-40°F to 194°F)
Temperature measurement resolution	0.01° or 0.1°, selectable
Temperature reading	°C or °F, selectable
LCD Display	8 characters

### Hazardous environments approvals

ATEX	II 1 G EEx ia IIB T4 / Tamb 50°C
Factory Mutual (FM Approvals)	CL I, DIV 1, GP C&D, T4 Tamb 50°C and CL I, ZN 0, AEx ia IIB T4 Tamb 50°C

### Multifunctions-Sensor

Ullage detection	ultrasonic
Interface detection	conductivity
Temperature	Platinum RTD Pt 1000
Innage / Reference height	additional load (option)

### Tape cleaning device

UP / DOWN tape cleaner

### Maintenance

modular design / easy exchange of parts

Specifications subject to change without notice.

## 11. Spare parts

### 11.1 How to proceed

Each spare part is identified by the letters TS followed by a 5 digits number, as for instance TS 10207 for the sensor or TS 10197 for the 15 meters tape.

Proceed as follows to identify the part you need to order:

- 1) Find the adequate drawing on the next pages;
- 2) Note the item TS number, ex. TS 10207;
- 3) With the assistance of the below table, identify its description, ex. "Sensor Ultra".

For each order, please note the item number, its description and the required quantity.

Example: TS 10207 "Sensor Ultra", 3 x.

### 11.2 List of parts descriptions

TS number	Description	Notes
10189	Battery holder assy	does not include TS 40300 & 37020
10190	Electronic box assy	does not include TS 11210 & TS 40765
10197	Tape 15m stand. double assy	kit (tape + 1 x TS 11603 + 1 x TS 40853)
10198	Tape 30m stand. double assy	kit (tape + 1 x TS 11603 + 1 x TS 40853)
10199	Tape 35m stand. double assy	kit (tape + 1 x TS 11603 + 1 x TS 40853)
10200	Tape 15m chem. double assy	kit (tape + 1 x TS 12509 + 1 x TS 40853)
10201	Tape 30m chem. double assy	kit (tape + 1 x TS 12509 + 1 x TS 40853)
10202	Tape 35m chem. double assy	kit (tape + 1 x TS 12509 + 1 x TS 40853)
10207	Sensor Ultra	
10210	Display unit assy	
11098	Pulley	
11114	Earth strap with clamp	kit (cable + 1 x TS 40116 + 1 x TS 40328)
11150	Zero indicator	
11152	Finger	
11155	Handle Mr.40p-M8 X 20	
11202	UNI Sensor protection	
11207	Axle bearing	
11208	Bearing for tape cleaner	
11209	Belt	
11210	Tape holder	
11211	Electronic box	
11213	Button handle	
11214	Connecting lever	
11216	Spacer	
11217	Gasket for electronic unit	
11218	Finger for handle	
11223	Knob	
11227	Washer holder	
11228	Screw cup	
11232	Load 500 gr.	
11235	Plate for battery holder	

11240	Wiper holder	
11243	Tube for sensor / Protection	
11244	Washer guide	
11245	Washer sensor visc	
11246	Spring for battery holder	
11248	Gasket for battery holder	
11249	Battery holder	
11257	Reel axle assy	
11259	External part of knob	
11260	Knob for handle	
11262	Bearing of pulley	
11263	Front face assy	without gasket
11267	External reel flange	
11269	Frame Otex	
11270	Base plate	
11283	Pipe clamp	kit (plates and screws)
11286	Protection tube	
11600	O-Ring Ø31x2	
11603	O-Ring Ø15x3	
12047	Lever	
12086	Gasket for electronic box	
12107	Wiper Viton	
14093	Spring	
35069	LCD 1x8 alphanumeric assy	
37004	Buzzer SC 235 B	
37020	Bat 9v alka mang Procell MN 1604	
37314	Push Button Distancer	
37340	PCB Display UTImeter Tested Assy	
37354	Hard Paper Washer 2.2mm	
40115	Toothed lock washer M4	
40118	Washer M8	
40220	Dowel pin 3x35	
40300	Socket head cap screw M3x8	
40303	Socket head cap screw M4x12	
40306	Socket head cap screw M3x10	
40316	Socket head cap screw M3x6	
40328	Socket head cap screw M4 x 6	
40555	Spacer M-M M3x6/M3x8	
40611	Slotted flat head mach. screw M5x16	
40621	Flat head socket screw M5x12	
40622	Flat head socket screw	
40628	Flat head socket screw M8 x 30	
40774	Socket button head cap screw M4x6	
40775	Cover cap S6	
40776	Socket button head cap screw M4x12	
40853	Socket set screw M3x3	
40857	Socket set screw M4x6	
40862	Socket set screw M4x6	
40906	Crescent ring Ø17 Benzing	

### **11.3 Spare parts drawings**

The next pages show the following drawings:

- Figure 11-1 : general assembly HERMetic UTImeter Otex standard version, list of the main spare parts
- Figure 11-2 : general assembly HERMetic UTImeter Otex chem version, list of the main spare parts
- Figure 11-3: display unit assembly TS 10210, details
- Figure 11-4: battery holder assembly TS 10189, details
- Figure 11-5: electronic box assembly TS 10190, details
- Figure 11-6: french base plate
- Figure 11-7: Visc
- -Figure 11-8: pipe clamp assembly
- Figure 11-9: tape cleaner, details

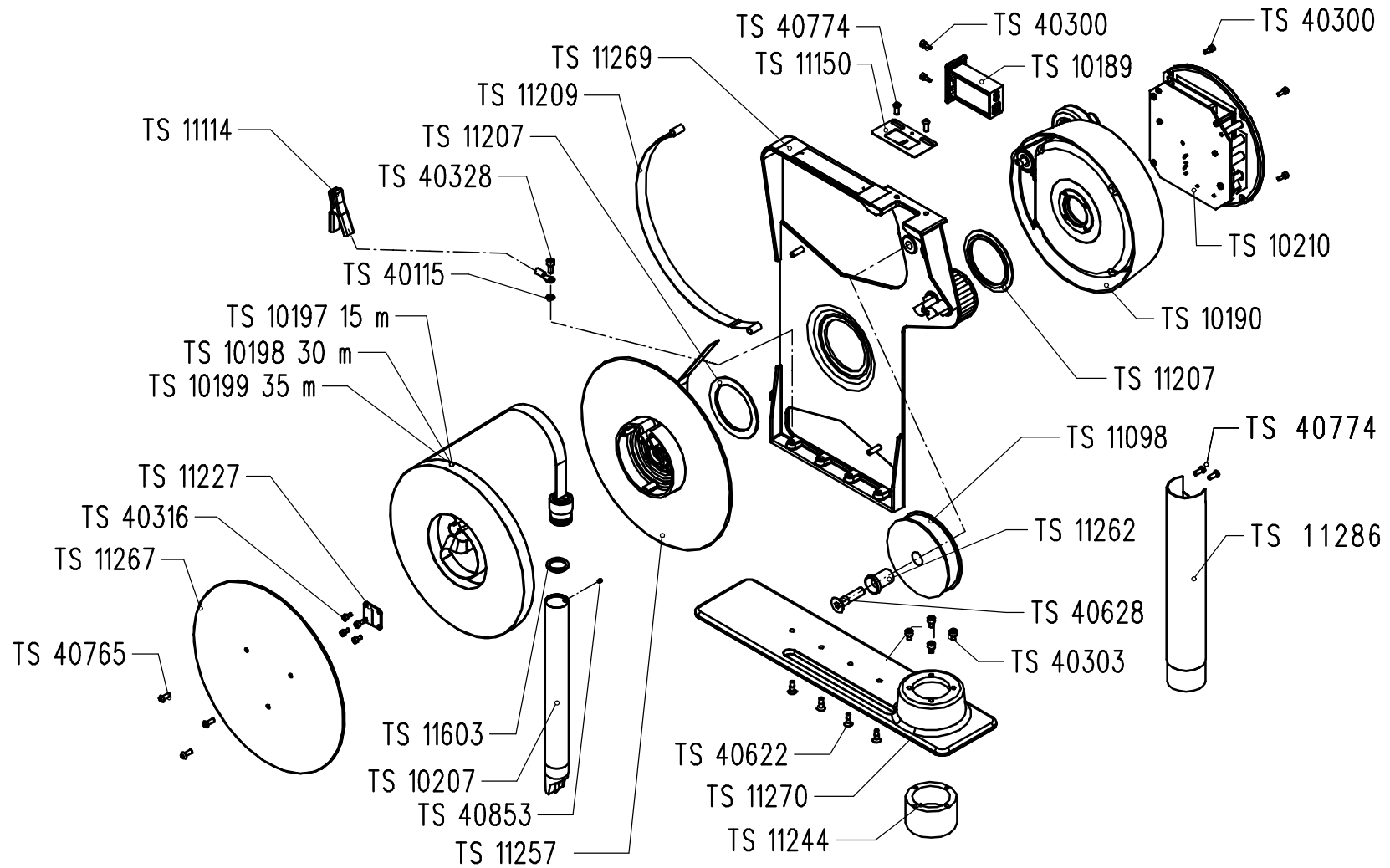

Figure 11-1 : general assembly HERMetric UTImeter Otex standard version, list of the main spare parts

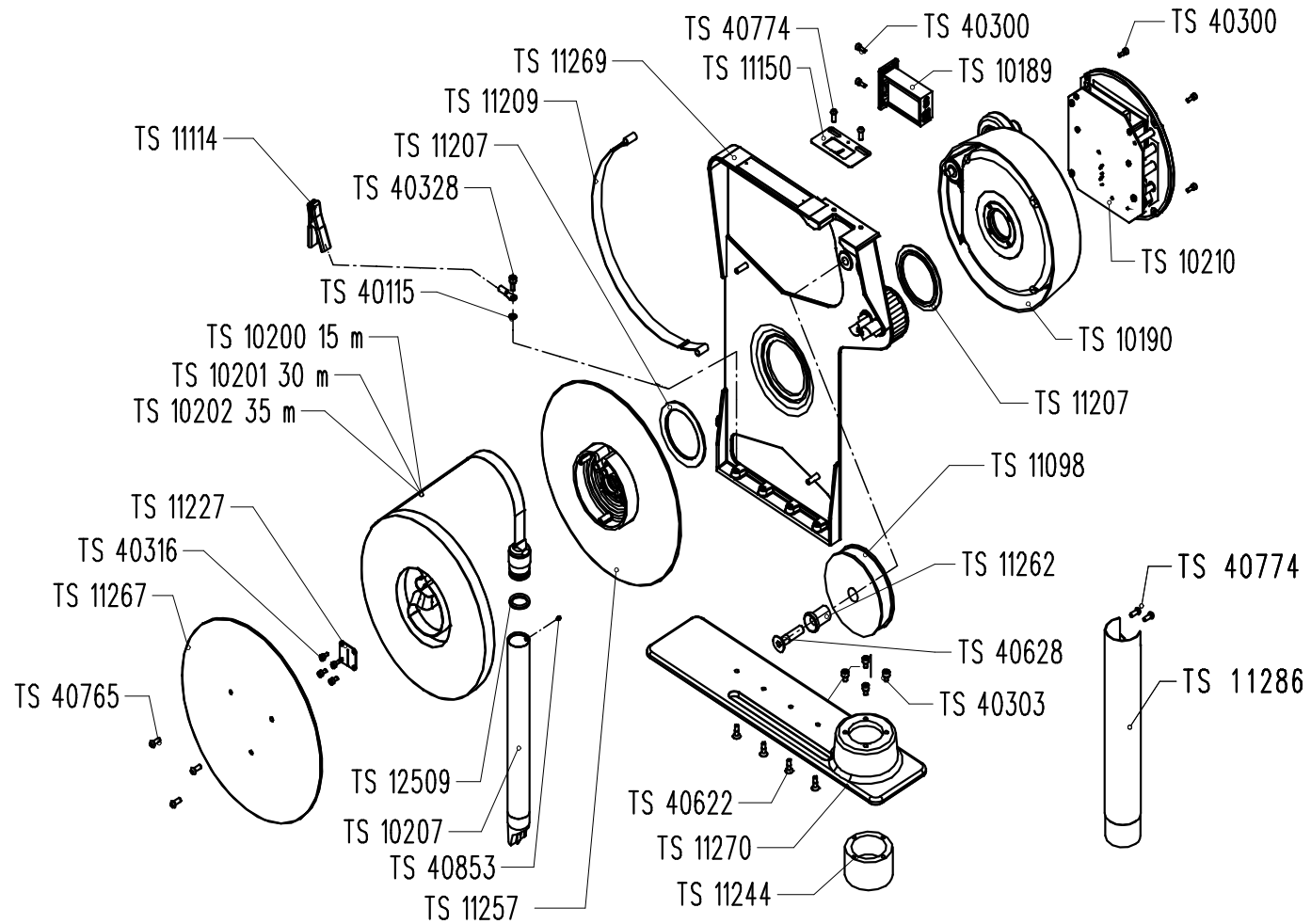

Figure 11-2 : general assembly HERMeTic UTImeter Otex chem version, list of the main spare parts

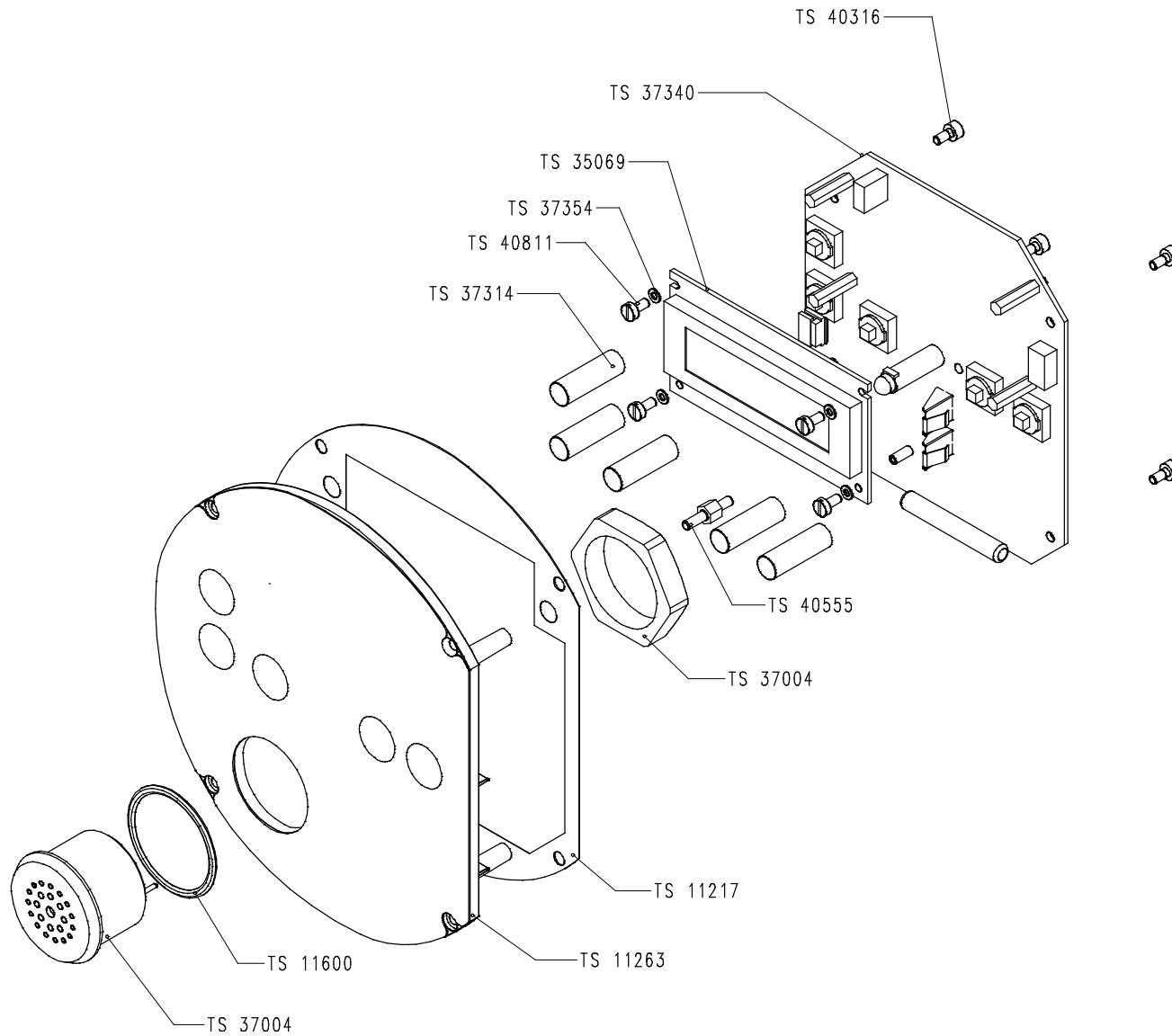
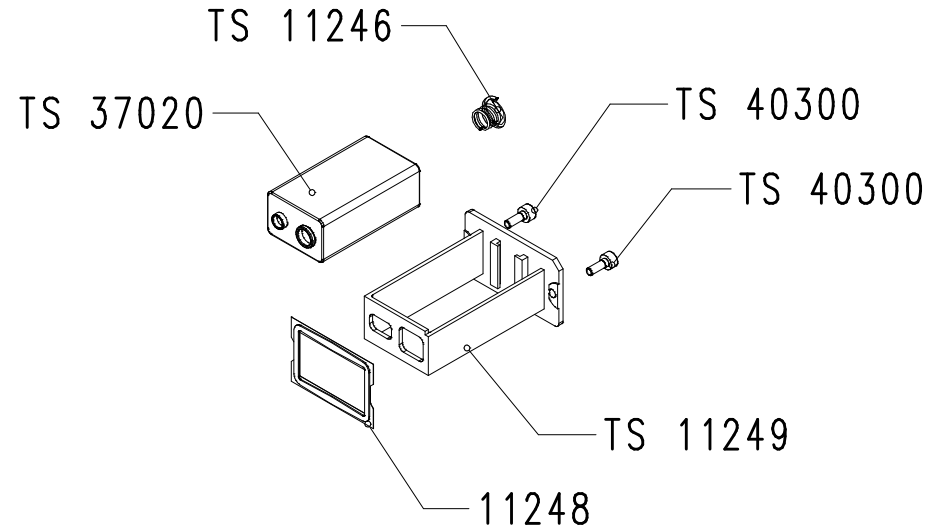
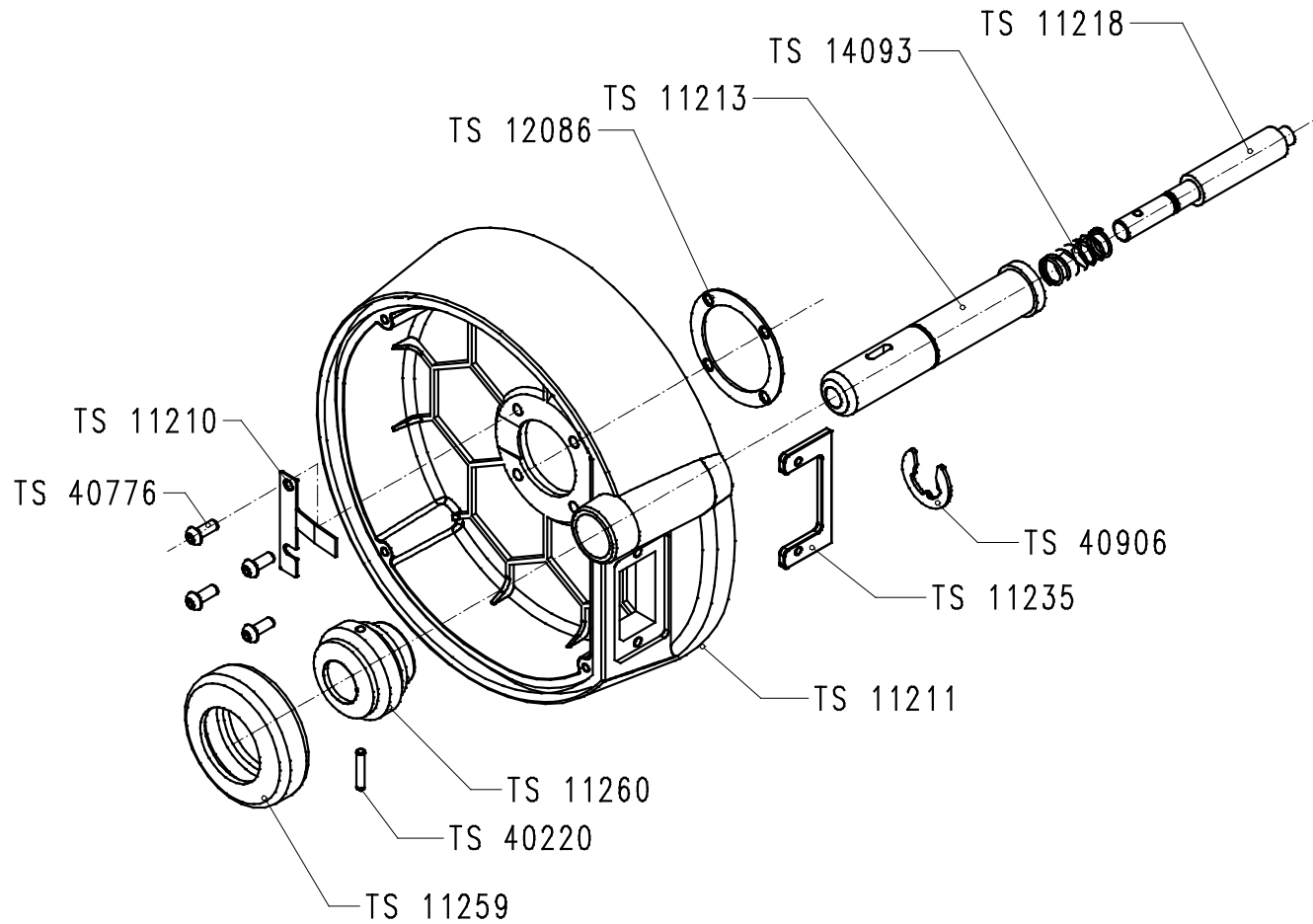

Figure 11-3: display unit assembly TS 10210, details





**Figure 11-4: battery holder assembly TS 10189, details**  
(the screws TS 40300 are not included in the TS 10189 assembly; they shall be ordered separately)



**Figure 11-5: electronic box assembly TS 10190, details**

**(the screws TS 40776 and the plate TS 11210 are not included in the TS 10190 assembly; they shall be ordered separately)**

**Screws TS 40776 must be glued when fitted)**

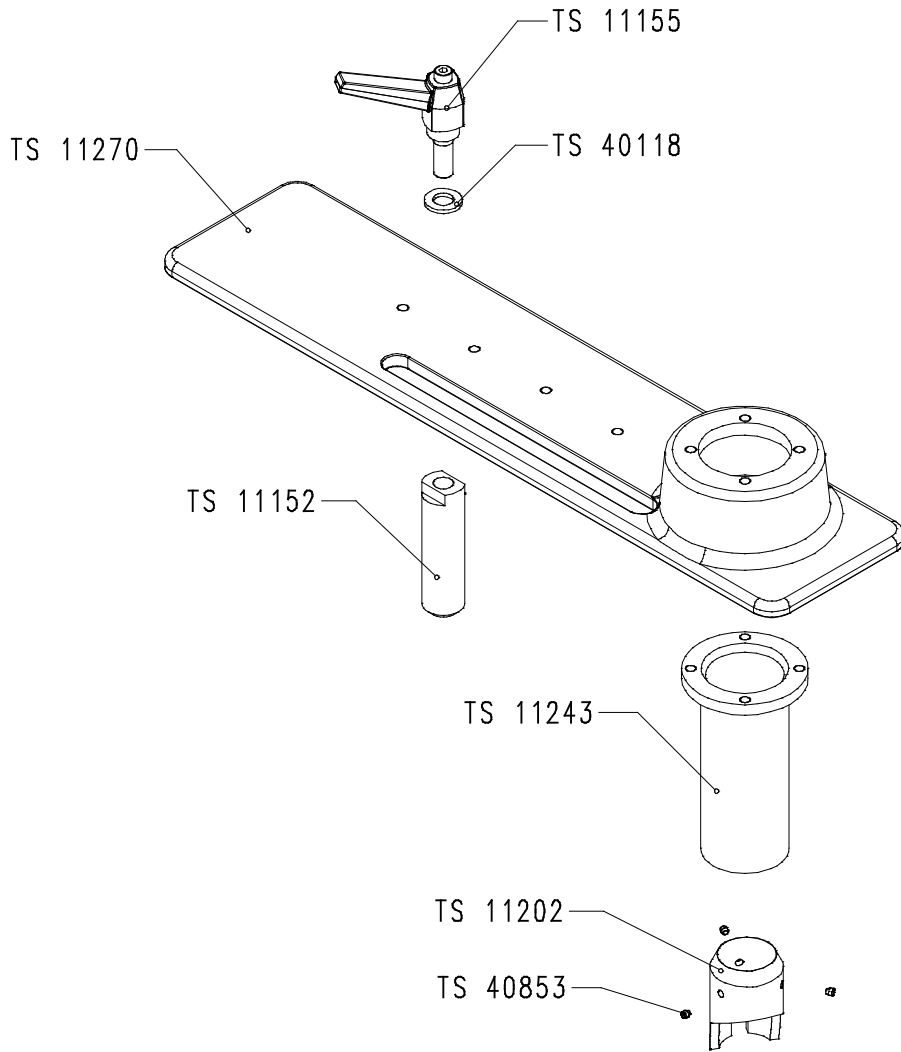

**Figure 11-6: french base plate**

For 0 reading index adjustment on tape use 6mm spacer (see Verification and adjustment of the reading index 8.9)

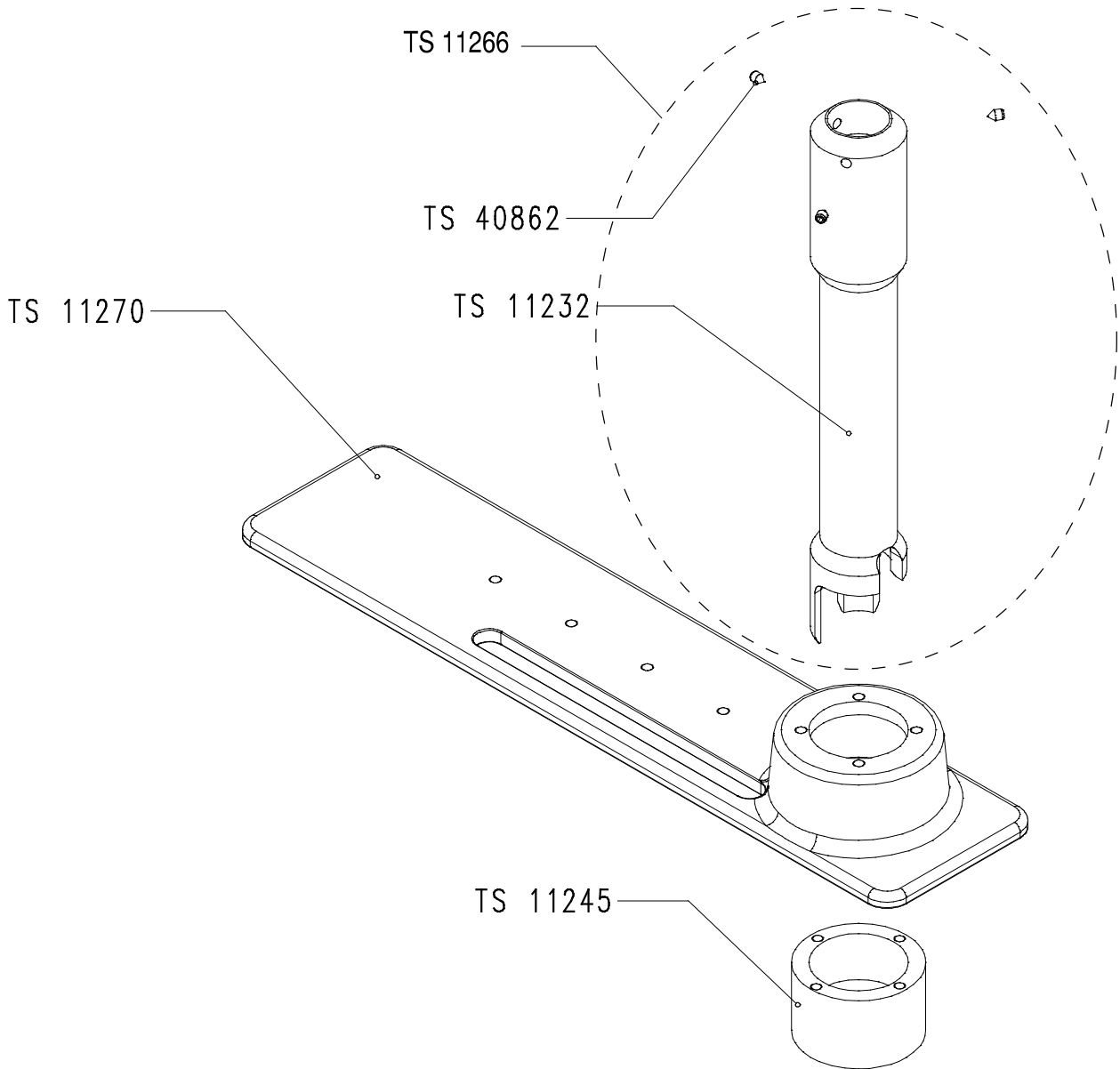

**Figure 11-7: Visc base plate**

For 0 reading index adjustment on tape use 6mm spacer (see Verification and adjustment of the reading index 8.9)

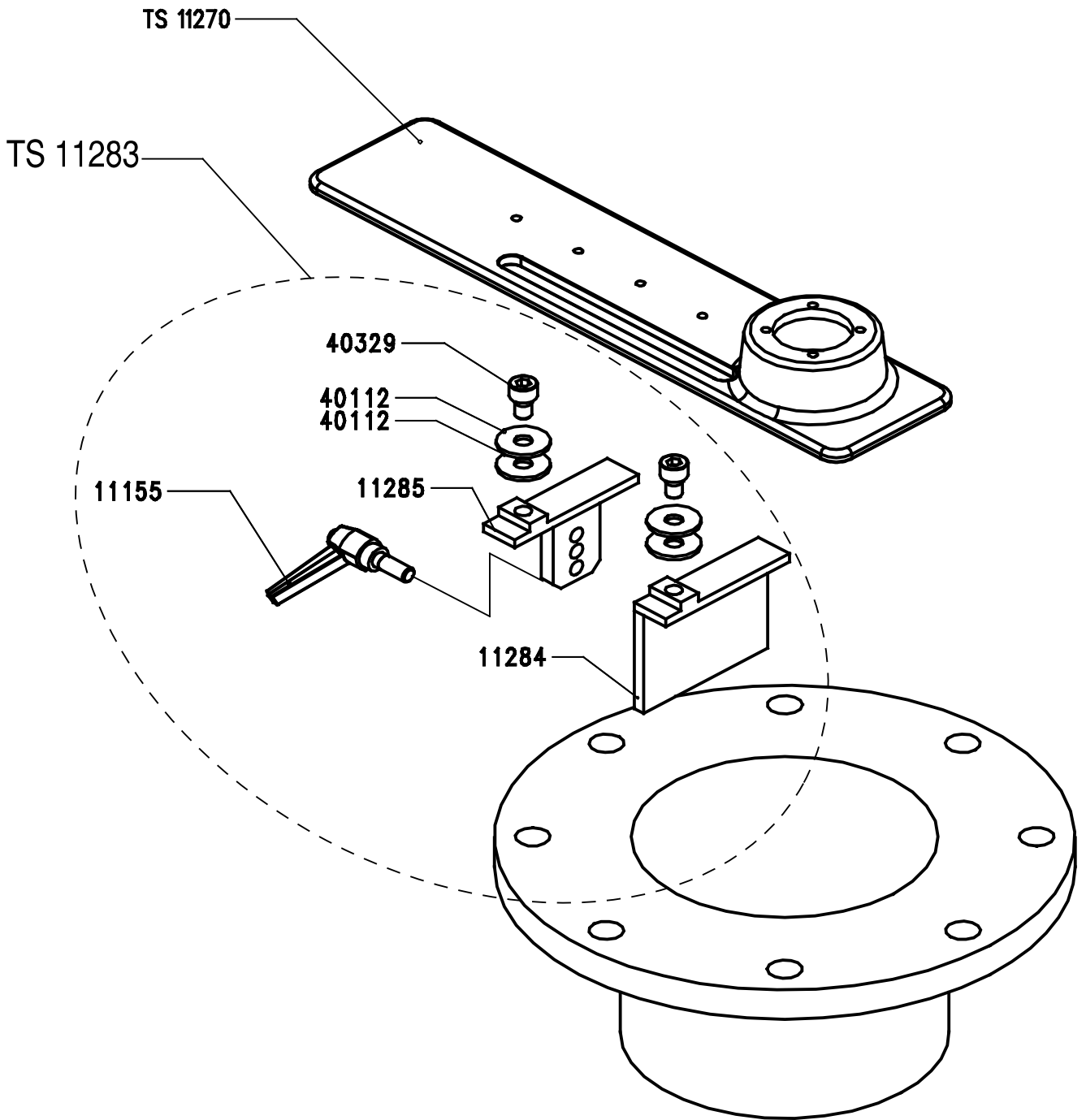

Figure 11-8: pipe clamp assembly

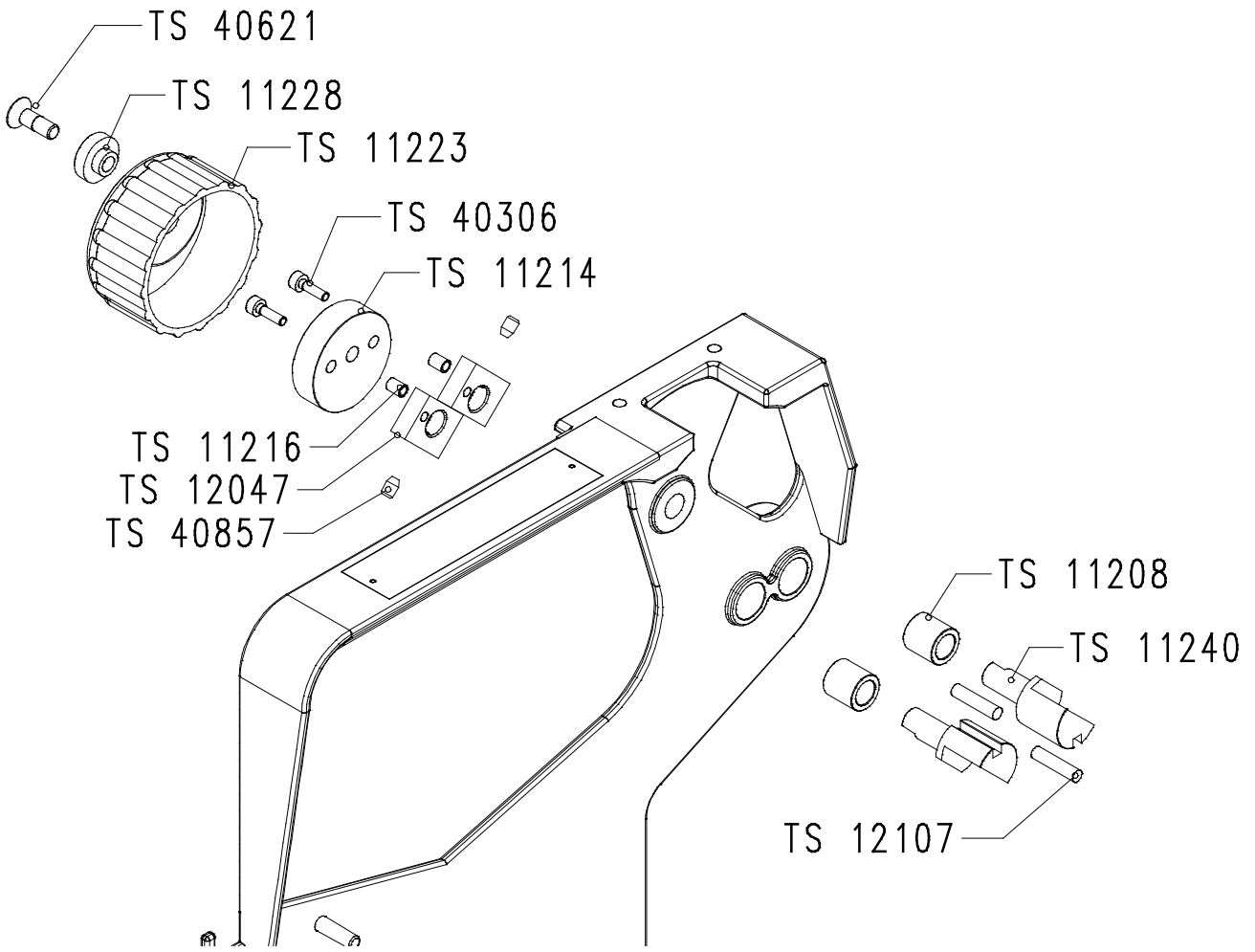

Figure 11-9: tape cleaner, details

