

Tiger Professional Lever Hoist Model No. PROLH



Main Features

- DNV GL Verification tested according to NORSOK R-002
- UK Network Rail PADS Certification
- Available with slipping clutch overload protection
- Range from 800kg – 20000kg
- Available with forged clevis adaptor components or shipyard hooks
- Equipped with our unique intelligent dual brake system:
 - Globally patent protected Quad Cam pawl and ratchet design
 - Unique load sensing torsion brake
- Thousands of hours of empirical evidence as proof of design
- One-piece construction pinion gear
- Light load tested and certified at 2% of the rated capacity
- No requirement for preload tension to activate the ratchet mechanism
- Adaptable to use both inverted and horizontally
- Each hoist is individually proof tested at 1.5 times the rated capacity
- Using only the highest quality alloy calibrated load chains according to EN 818-7 and ISO 16872
- Individual spares readily available
- All major parts are heat treated and precisely machined
- Can be chained up to meet your exact requirements
- Finished in high quality powder coat paint offering excellent corrosion protection
- Operating temperature -40°C to +80°C (temperature range of -60°C to +80°C available as an option)
- Also available with stainless steel load chain or spark resistant hooks
- Available with load bearing swivel hooks to meet relevant standards i.e. AS 1418.2



with spark resistant components



with optional travelling end stop



with overload protection

Tiger PROLH lever hoists incorporate many of the advanced safety features that Tiger has developed including one-piece construction pinion gears, our unique intelligent dual brake system and our patented Quad Cam Pawl System. These units meet and exceed all the requirements within BS EN 13157: 2004+A1:2009, ANSI/ASME B30.21, AS1418.2 and SANS 1636.

The PROLH is ideally suited for applications in the overhead transmission industry, shipyards and offshore platforms and is also suitable for underground mining use.

With over 50 years of professional manufacturing experience, Tiger's commitment to innovation and customer satisfaction mean we will continue to develop and improve our products by communicating and working with our customers.

Certification:

Each unit comes fully certified with a test certificate or an EC Declaration of Conformity stating compliance with the essential health and safety requirements of the Machinery Directive 2006/42/EC. This document clearly states the proof test at 1.5 times the rated capacity and the light load test of 2% of the rated capacity, which exceeds the requirements of the current applicable standard.

UK Network Rail PADS Certification:

Our PROLH lever hoist has UK Network Rail PADS Certification - Certificate of Acceptance PA05/06651

Safety Brake:

The PROLH includes our unique rotational inertia driven torsion switch brake and freewheeling system. This brake system was designed by our research and design team to counter known failure modes in commonly used and copied longitudinal "push-pull" mechanisms or traditional style "Weston" type brake systems used on alternative lever hoists which allow easy ingress of foreign particles into the mechanism that could affect hoist operation. Our design removes the need for inefficient old-style longitudinal disengagement methods of pulling the brake system apart to facilitate freewheeling.

Our unique brake system automatically engages when the lever hoist feels the slightest resistance or load meaning there is no requirement for preload tension to activate the ratchet mechanism. This key feature means that the PROLH will raise, hold and lower the lightest of loads without slipping. The two-stage process protects against accidental light load failures by putting the hoist into neutral whilst under load. (To achieve complete neutral the switch gear must be aligned which is impossible to do whilst under load.) This highly efficient method of operating is not only safer but easier for the operator whilst measurably increasing the brake take up efficiency rate.

This Tiger brake system is now a proven design with many thousands of hours of empirical evidence as proof of design and efficiency. This design is fully utilised throughout our PROLH range offering topside professional users unprecedented access to the most highly efficient lever hoist brake system on the market.

The bonded marine friction discs are free of asbestos and have been developed and designed to create a highly efficient, reliable braking surface.

Light Load Protection:

The unique brake system designed for the PROLH guarantees a light load protection at 2% of the rated capacity.



Brake Efficiency:

Tiger PROLH lever hoists utilise an 8 point multi-start thread pinion shaft which doubles the lead distance compared with typical 4 point threaded shafts, increasing the brake efficiency by 100%. The rotational engagement of the brake works with the direction of the load sheave creating highly efficient braking ratios. With our fine manufacturing tolerances between the pinion shaft thread and critical brake components we have engineered out a known failure mode where contamination to the threads can lead to brake failure or slippage.

Patent Protected Quad Cam Brake Pawl System:

Our patented Quad Cam Pawl System guarantees permanent engagement of at least one of the two reciprocating cam pawls fitted to the PROLH, ensuring the pawl only just clears the ratchet wheel, with the minimum of clearance as required under BS 4898:1973. But most importantly, in the unlikely event of a pawl spring failure, this design will ensure the brake is still fully functional and the load is sustained without damage to the mechanism.

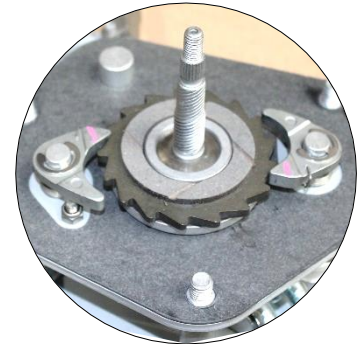

One Piece Construction Pinion Gears:

PROLH gearboxes contain one-piece pinion gears. This revolutionary process in gear manufacturing uses drop-forged raw material, precision machined and heat treated with precise ratios between teeth and body.

Overload Protection:

The PROLH lever hoist can be fitted with a slipping clutch overload mechanism to protect it from overload. When the load limit is exceeded, the clutch in the chain wheel will slip, allowing the handle to be operated whilst not engaging the gear box. This prevents further lifting of the load, though lowering is still possible. The PROLH with overload protection is DNV GL Verification tested according to NORSOK R-002.

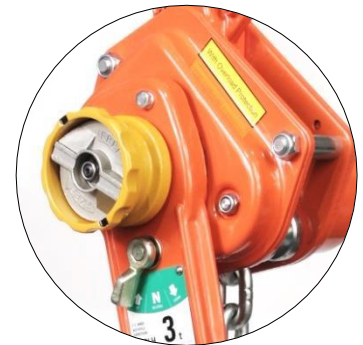

Chain End Stops:

User friendly heavy duty end stops make it easy for the operator to position the chain while "freewheeling", but most importantly this "end stop" will hold a load of at least 2.5 times the rated capacity when supporting the full load without restraint from other components e.g. brake or gearing.

Optional Travelling Chain End Anchorage:

Our specially designed adjustable chain end stop is available as an option. Tiger have specifically profiled and manufactured this item to fit the contours of the hoist. This offers complete assurance to the operator, whilst maintaining the flexibility of "freewheeling" the chain to any required starting position.





Hooks:

Our hooks incorporate our patented “EZ Check” feature which allows operators and inspection engineers to easily check to see if the hoist has been previously overloaded or shock loaded by simply measuring between the triangle of pop marks.



Our drop forged and heat-treated alloy hooks are furnished with heavy duty spring latch kits that fully engage into the recessed nose of the hook safeguarding the load when side loading of the latch occurs and offering maximum load security. The swivel hooks are attached to the yoke using high grade nuts & bolts allowing for complete inspection during any statutory inspection or written scheme maintenance.

Available with hooks that swivel under the full working load limit, to meet relevant standards i.e. AS 1418.2. Also available with spark resistant hooks.

Chain Stripper:

The chain stripper is specifically designed to guide the load chain safely onto or off the load sheave without snagging or jamming. The fluted chain stripper allows the safe use of the PROLH when used in any orientation.



Forgings:

Recessed forgings offer full protection to the load chain anchor bolts on all our bottom hooks.

High Performance Premium Grease:

We use new technology, wide temperature range, high performance premium grease. It contains no heavy metals or other harmful additives making it more environmentally friendly. This selection achieves the correct viscosity to prevent the grease migrating from the area of application. Even when mixed with 50% high water absorption it has excellent adhesion and no sign of breakdown after 100,000 strokes and remains unchanged with no slump or breakdown unlike other “premium” greases. Load carrying ability, mechanical stability, corrosion protection, water resistance and increased operating temperature ranges are all improved by the using only the very best lubricant.

Temperature Range:

Standard operating temperature range -40°C to +80°C - far exceeding the requirements of current standards. Ultra-low operating temperature units (-60°C to +80°C) also available.

Load Chains:

Tiger only use the highest quality alloy, calibrated load chains in Grade T or VH conforming to EN818-7 and ISO 16872. The PROLH comes as 1.5mtr HOL as standard but can be chained up to whatever length is required. Stainless steel load chain available on request for certain capacities.

Finish:

The PROLH is finished in our high-quality powder coat paint offering excellent corrosion protection.

Mechanical Efficiency:

All major components are heat treated and precisely machined to ensure long term smooth operation. High gear ratios keep physical effort to a minimum.

Handle:

Tiger lever hoist handles are ultra-strong, with strengthening side ribs. This special feature:

- Protects against impact damage
- Protects the label
- Increases its robustness and longevity
- Eliminates torsion.



Adaptor Components

Drop forged adaptor maintaining maximum strength. 360° Rotation and 180° Pivot for Maximum Flexibility. Tested and certified to 4:1 factor of safety.



Self-locking (safety) hook, clevis shackle, reevable egg (master) link or sling hook fittings available (for units up to 10t capacity).

Performance:

The PROLH lever hoist has undergone a full test program that includes:

Type Testing

- Ultimate strength test, at least 4 times the Working load limit (WLL)
- Chain end anchorage test, passing at least 4 times the WLL without any restriction of the brake or gears

Test on every hoist

- Proof loading at 1.5 times the rated capacity
- Light load testing at maximum of 2% rated capacity

Technical Data

Product Code	Capacity (tonne)	Effort (kg)	Dimensions (mm)							Load Chain		Standard HOL (m)	Mass @ std HOL (kg)	Mass for extra metre HOL (kg)
			A	B	C	D	E	F1	F2	Diameter (mm)	No. of falls			
PLH-0075	0.8	23	128	236	295	158	99	28	45	ø6.3	1	1.5	7.5	0.9
PLH-0150	1.5	26	154	360	320	172	104	34	51	ø7.1	1	1.5	10.5	1.1
PLH-0300	3.0	38	182	360	400	195	108	36	56	ø10.0	1	1.5	18.0	2.2
PLH-0600	6.0	40	242	360	570	195	108	49	70	ø10.0	2	1.5	28.5	4.3
PLH-1000	10.0	47	379	360	630	195	108	54	87	ø10.0	3	1.5	46.0	6.5
PLH-1500	15.0	44	566	360	840	195	108	59	81	ø10.0	5	1.5	112.0	10.8
PLH-2000	20.0	49	470	360	1050	250	160	81	110	ø10.0	6	1.5	156.0	13.1

See page 8 for more hook information

During 2020 our 1.5t/3.0t and 6.0t capacity PROLH hoists will change to 1.6t, 3.2t and 6.3t capacity PROLH hoists.

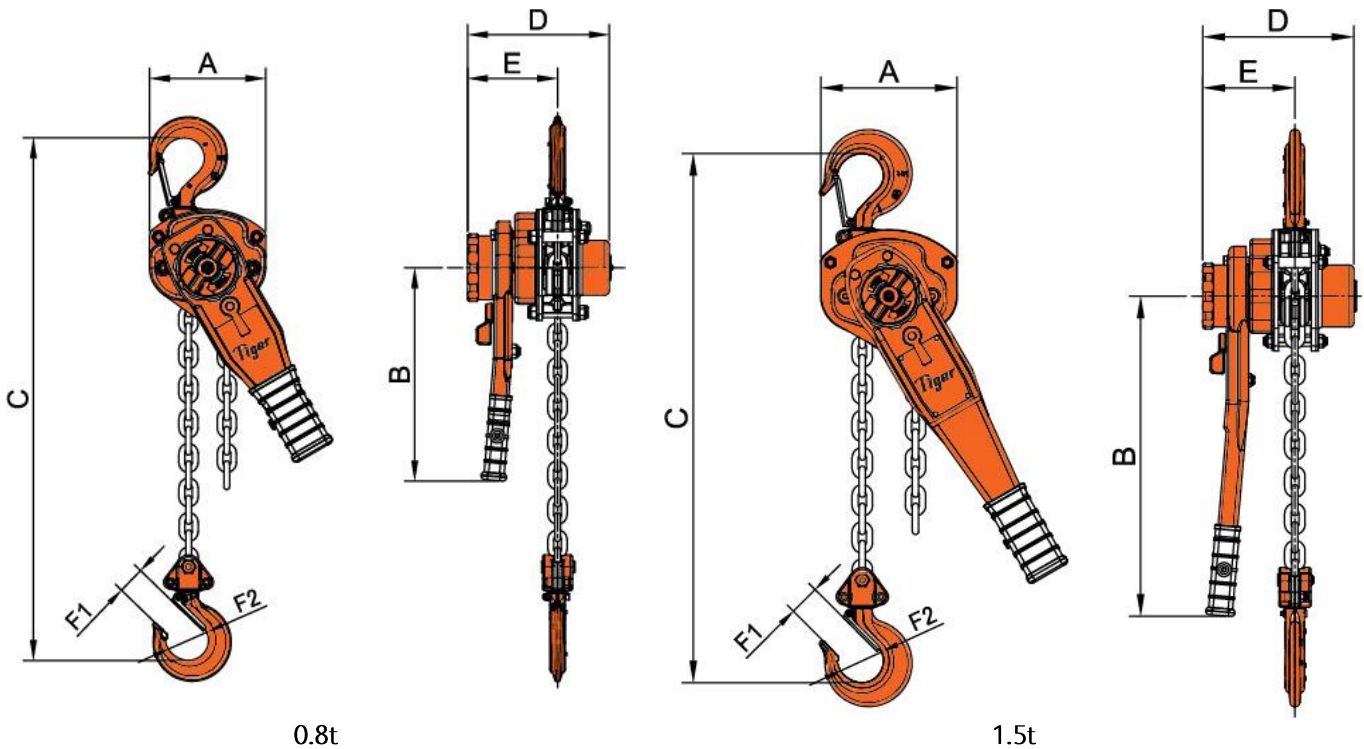

0.8t

1.5t

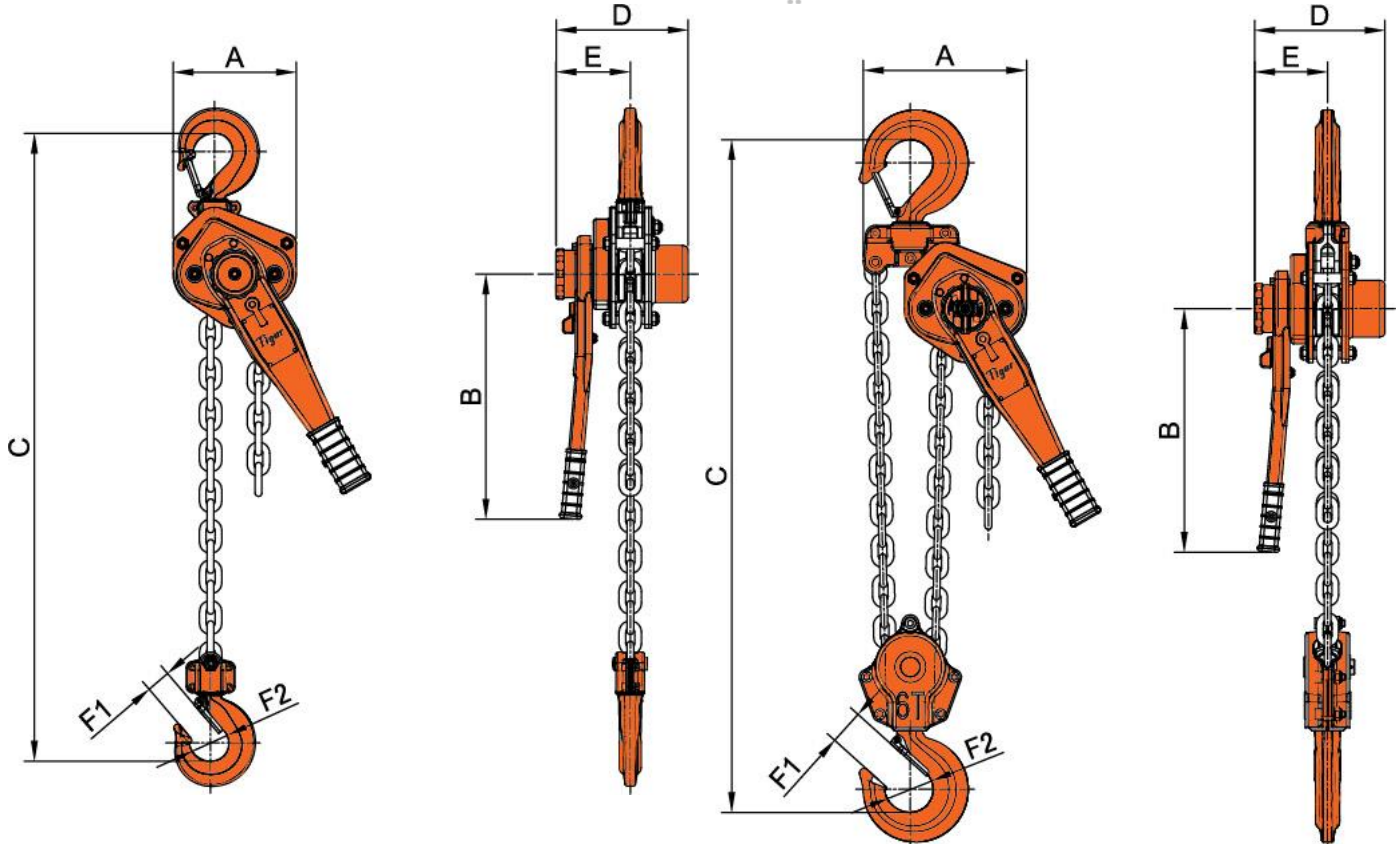

3.0t

6.0t

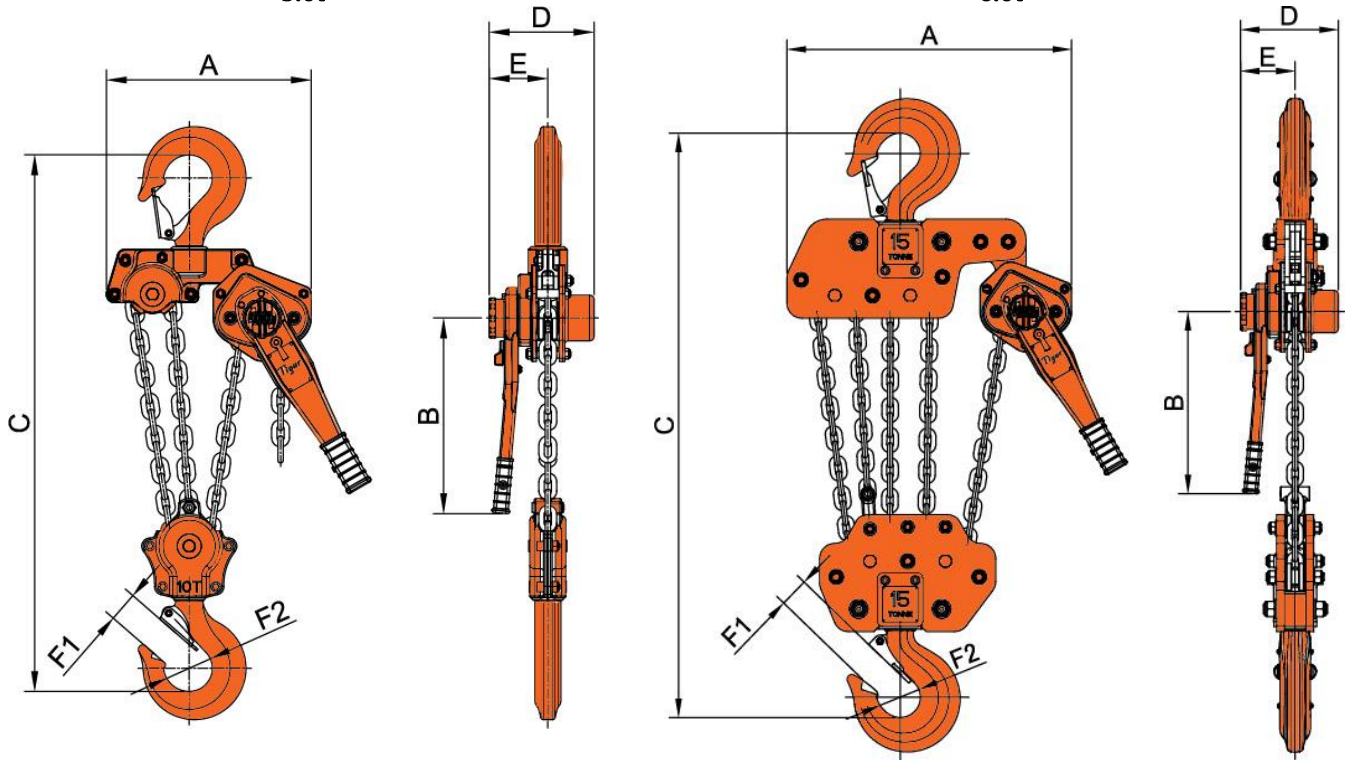

10.0t

15.0t

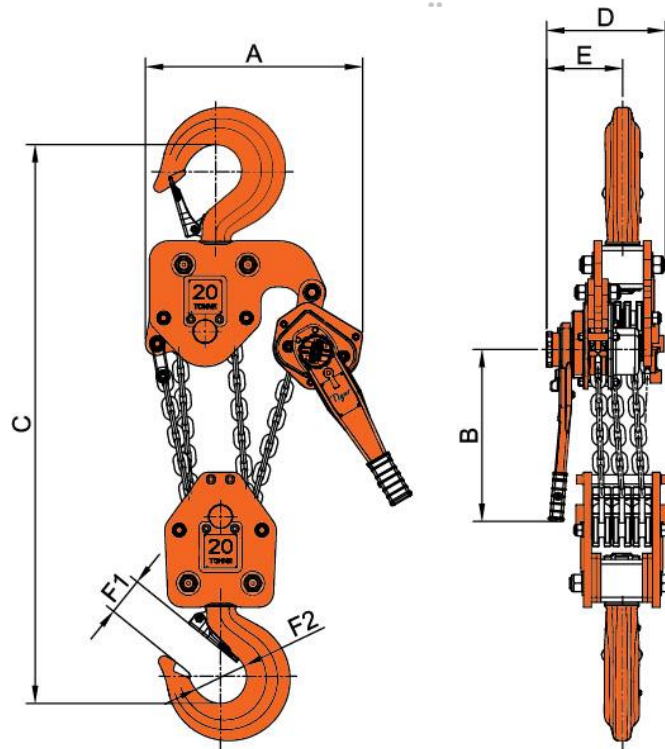

20.0t

Hook Technical Data

Capacity (Tonnes)	Collar measurements (mm)		Hook thickness at point shown in diagram (mm)		Hook throat Opening (mm)	"EZ Check" measurement (mm)
	a	b	c	d	e	f
0.8	8	13.5	23	17	34	52
1.5/1.6	10	15.5	26	21	39	59
3.0/3.2	12.5	20	37	32	42	76
6.0/6.3	19	30	43	36	58	86
10.0	20	33	52	48	70	121
15.0	-	36	67	60	67	130
20.0	-	48	77	72	90	162

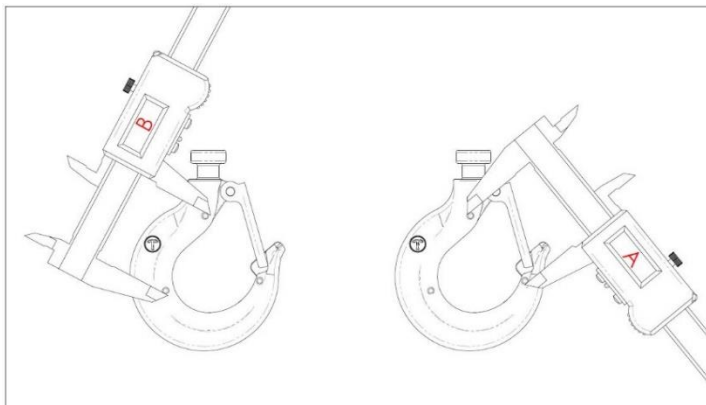
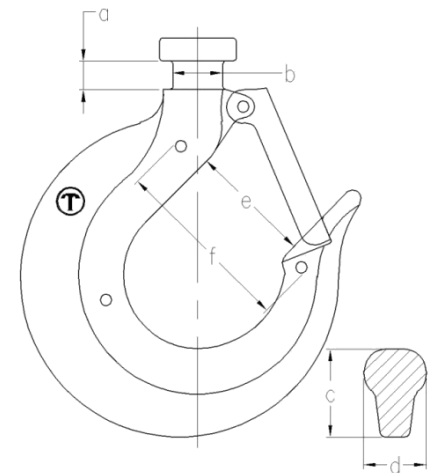

PROLH lever hoists are fitted with the patented Tiger "EZ check" 3 point marking system. With this system a quick check that the A and B measurements are the same (as shown in the diagram below) will indicate if the hooks have stretched. If $A \leq B$ the hook is fine; If $A > B$ the hook needs to be replaced.

Due to our policy of continual product development, dimensions, weights and specifications may change without prior notice. Please check with your Tiger sales team when ordering.

Bespoke designs available on request – contact info@tigerlifting.com for more information.