

# Short Reach Jib (SRX)

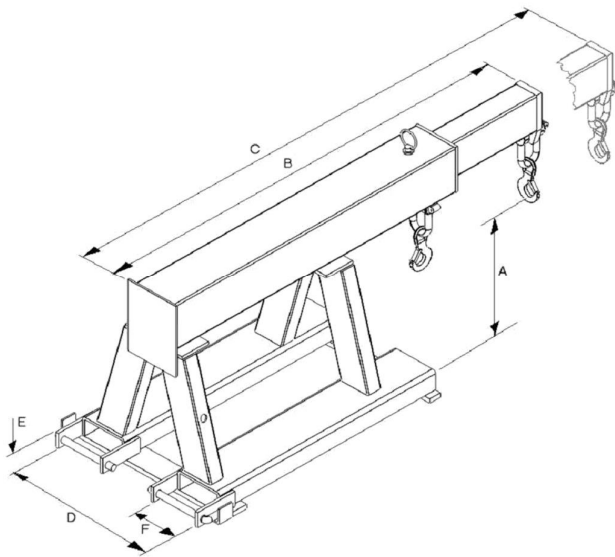

The Short Reach Extending Jib allows previously inaccessible loads to be handled safely. The jib can be fitted to a forklift simply; remove the heel pin and drive the truck slowly forwards until fully sleeved. Re-fit the heel pin behind the truck forks. Ensure the jib is fully secured before lifting.



Short Reach Extending Jibs allow transportation of long loads safely. The two hooks provided allow loads to be slung at greater centres than with a conventional jib. The greater length allows previously in-accessible loads to be handled. Manual Extension.

Model Ref	Weight	C of G Min	C of G Max
SRX 500-1.3	120kgs	554mm	628mm
SRX 500-1.8	120kgs	554mm	628mm
SRX 500-2.2	120kgs	554mm	628mm
SRX 500-2.7	160kgs	567mm	644mm
SRX 500-3.1	160kgs	567mm	644mm
SRX 500-3.5	160kgs	567mm	644mm

### Capacity (Kgs) @ Load Centres (mm)

Model Ref	1000	1250	1500	1750
SRX 500-1.3	680	500	450	380
SRX 500-1.8	1100	900	720	580
SRX 500-2.2	1400	1100	1000	850
SRX 500-2.7	1450	1200	1100	900
SRX 500-3.1	1900	1500	1200	1000
SRX 500-3.5	2000	1600	1300	1100

Model Ref	Truck Capacity	'A' Hook Height (mm)	'B' Closed Length (mm)	'C' Open Length (mm)	'D' Fork Spread (mm)	'E' Max Fork Thickness (mm)	'F' Fork Max Width (mm)
SRX 500-1.3	1500kg	191	1250	1750	496	50	125
SRX 500-1.8	2000kg	191	1250	1750	496	50	125
SRX 500-2.2	2500kg	193	1250	1750	496	50	125
SRX 500-2.7	3000kg	176	1250	1750	546	50	150
SRX 500-3.1	3500kg	163	1250	1750	546	50	150
SRX 500-3.5	4000kg	137	1250	1750	546	50	150