

cromox Grade 6 Swivel Lifting Points CDAW

The William Hackett Grade 6 cromox components are manufactured by KETTEN WALDER in Germany using the highest quality of stainless steel to achieve market leader quality products. All components are manufactured on state of the art modern machinery. These products are rigorously tested in house and form part of the cromox chain sling system. The cromox range of products use the highest levels of design, materials and manufacturing processes to produce the best performing products for use in the harshest environments. Due to the high quality, purity and narrow tolerances of alloying elements in cromox steel, we are able to produce durable, heavy duty stainless steel products with increased corrosion and crack resistance. The high concentrations of chromium ensures a strong and passive layer of chromium oxide for protection. The high concentrations of chromium and molybdenum allow for increased Working Load Limit (WLL)

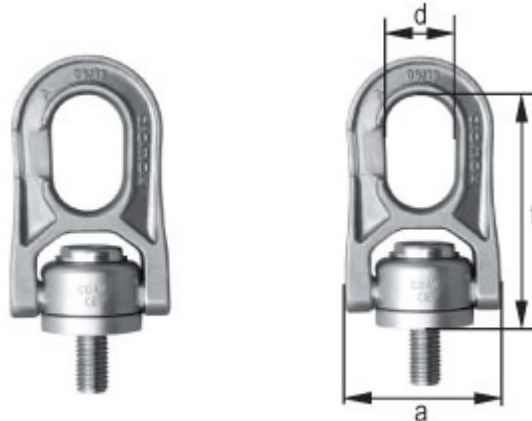

SPECIFICATIONS

Type	a mm	t mm	d mm	Thread	Wrench allen key	W.L.L. Tonnes	Mass Kg
SS-CDAWM-14	68	98.5	31.0	M14 x 26	22/10	1.00	0.49
SS-CDAWM-16	68	98.5	31.0	M16 x 26	22/10	1.25	0.50
SS-CDAWM-20	68	98.5	31.0	M20 x 30	22/10	1.55	0.51



Advantages

- 360° rotation and adjustable in any load direction
- Flattened section for combination with CGS
- High Fatigue-resistance through forged ring-body
- Easy fitting, dismounting using allen key 10 and wrench 22cm screw
- Tested acc. EN 1677-1, quadruple protection against breakage, grade 6
- All parts 100% crack detected
- Screw secured at ring body to prevent loss
- Duplex material 1.4462 (AISI 318LN) ensures superior corrosion resistance



Lifting Gear Store
c/o Safety Gear Store Ltd
The Mount
566 Eutruria Road
Newcastle Under Lyme
ST5 0SU