



Options

- Stainless steel load chain.
- Suspension hook rotated 90°.
- Flexible chain container.
- Other operating voltages.
- Limit switches for highest and lowest hook positions (in combination with low voltage control).
- Motor with stainless steel brake.
- Radio remote control
- Control for synchronized operation of several hoists.
- Manual and electric trolleys.
- Integrated low headroom trolley.
- Connection to festooned cable systems.

Electric chain hoist model CPE with suspension hook or with integrated trolley

Capacity 1600 - 10000 kg

The CPE series is a range of high quality products for professional applications. They are highly efficient and engineered for a long working life. The hoists are composed of three main component parts which makes service easy and inexpensive.

Features

- Classification: 1 Am/M4, except models CPE(F) 20-8, CPE(F) 30-5 and CPE(F) 40-4 classification 1 Bm/M3. As required the model CPE (with appropriate changes to lifting capacity resp. duty cycle) can also be re-classified.
 - Direct control or 42V low voltage control.
 - 2 year warranty (excluding wear parts) as well as a lifetime lubricated gear box.
 - Motor fitted with a bimetallic thermal protection (useable in connection with low voltage control).
 - Duty cycle 40% at one operating speed.
 - The heavy duty squirrel cage motor has an adjustable spring pressure brake that holds the load secure even in the event of a power failure.
 - Standard operating voltage:
Euro-voltage 400 Volt, 3-phase, 50 Hz.
 - Motor protected to IP 54, insulation class F, against ingress of dust and splashing. (acc. to VDE 0530)
 - Encapsulated pendant control protected to IP 65, against ingress of dust and water jets.
 - Up to 3000 kg only one chain fall, leading to a low overall height.
 - The 5-pocket load chain sheave, manufactured from wear resistant case hardening steel, is matched perfectly to the load chain to guarantee smooth and precise chain motion.
 - The standard, oil bath lubricated planetary gearbox is particularly smooth running.
 - Drop forged suspension and load hooks are made from non-aging, high tensile steel and fitted with robust safety latches.
 - The standard case hardened and zinc-plated link chain is matched perfectly to the load chain to guarantee smooth and precise chain motion.
- All requirements of national and international standards and regulations are fulfilled.

Twin hoist model CPE 100-2

Capacity 10000 kg

The model CPE 100-2 consists of two CPE 50-2 units.

They are connected by a framework.

Hook suspension, geared or electric trolleys are available.

Integrated limit switches for highest and lowest hook positions are standard.

42V low voltage control as standard.

Options

- Stainless steel load chain.
- Flexible chain container
- Other operating voltages
- Motor with stainless steel brake.
- Radio remote control
- Festooned cable system



Festooned cable systems
see pages 138-139.



5-pocket load chain sheave machined for smooth, precise chain motion.



Universal connection to suspension hook, trolley or steel structures.



Double fall bottom block for capacities between 3200 up to 5000 kg.

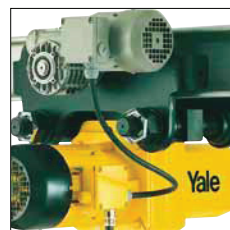

Hoist connected directly to trolley with electric drive. Manual pull and geared trolleys also available.



Option: Flexible chain container made from wear resistant textile fabric.

The units are certified by the employer's liability insurance association (Berufsgenossenschaft) and fulfil the requirements of the machinery directive 2006/42/EG.



Compact planetary gearbox

Electric chain hoist with low headroom integrated trolley

Zinc-plated Yale load chain

! Yale hoists and trolleys are not designed for passenger elevation applications and must not be used for this purpose.

! All capacities and speeds of the standard model CPE are also available for the CPE LH version.

Push-button pendant control, IP 65

Technical data model CPE/CPEF

Model	EAN-No. 4025092*	Capacity in kg/ number of chain falls	Chain dimensions d x p mm	Classification FEM/ISO	Lifting speed main lift m/min	Lifting speed fine lift m/min	Hoist motor kW	Motor rating ED %
CPE 16-8	*073240	1600/1	11x31	1Am/M4	8	-	2.3	40
CPEF 16-8	*073257	1600/1	11x31	1Am/M4	8	2	2.3/0.58	40/20
CPE 20-8	*073264	2000/1	11x31	1Bm/M3	8	-	2.8	25
CPEF 20-8	*073271	2000/1	11x31	1Bm/M3	8	2	2.8/0.7	25/15
CPE 25-5	*073288	2500/1	11x31	1Am/M4	5	-	2.3	40
CPEF 25-5	*073295	2500/1	11x31	1Am/M4	5	1.25	2.3/0.58	40/20
CPE 30-5	*073301	3000/1	11x31	1Bm/M3	5	-	2.8	25
CPEF 30-5	*073318	3000/1	11x31	1Bm/M3	5	1.25	2.8/0.7	25/15
CPE 32-4	*073325	3200/2	11x31	1Am/M4	4	-	2.3	40
CPEF 32-4	*073332	3200/2	11x31	1Am/M4	4	1	2.3/0.58	40/20
CPE 40-4	*073349	4000/2	11x31	1Bm/M3	4	-	2.8	25
CPEF 40-4	*073356	4000/2	11x31	1Bm/M3	4	1	2.8/0.7	25/15
CPE 50-2	*073363	5000/2	11x31	1Am/M4	2.5	-	2.3	40
CPEF 50-2	*073370	5000/2	11x31	1Am/M4	2.5	0.6	2.3/0.58	40/20
CPE 75-1,6	*079907	7500/3	11x31	1Am/M4	1.6	-	2.8	40
CPEF 75-1,6	*079914	7500/3	11x31	1Am/M4	1.6	0.4	2.8/0.58	40/20
CPE 100-2	*060585	10000/4	11x31	1Am/M4	2.5	-	2x2.3	40
CPEF 100-2	*060592	10000/4	11x31	1Am/M4	2.5	0.6	2x2.3/0.58	40/20

Model	Weight* suspension hook kg	Weight* push trolley kg	Weight* geared trolley kg	Weight* electric trolley** kg
CPE 16-8	88	150	154	164
CPEF 16-8	93	155	159	169
CPE 20-8	88	150	154	164
CPEF 20-8	93	155	159	169
CPE 25-5	88	150	154	164
CPEF 25-5	93	155	159	169
CPE 30-5	88	150	154	164
CPEF 30-5	93	155	159	169
CPE 32-4	107	169	173	182
CPEF 32-4	112	174	178	187
CPE 40-4	107	169	173	182
CPEF 40-4	112	174	178	187
CPE 50-2	107	169	173	182
CPEF 50-2	112	174	178	187
CPE 75-1,6	220	320	320	340
CPEF 75-1,6***	226	326	326	346
CPE 100-2	282	-	385	406
CPEF 100-2***	287	-	390	411

* Weight at standard lift (3m). Other lifting heights on request.

** Additional weight for 2 speed version 2.0kg

*** Limit switches for highest and lowest hook positions – 42V low voltage control.

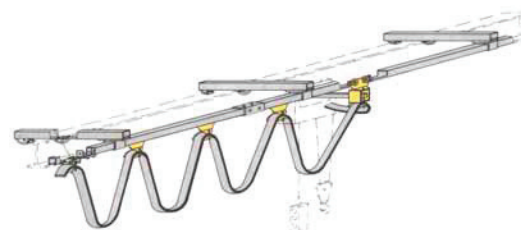

Festooned cable systems
see pages 138-139.



Technical data trolleys

Capacity kg	Size	Beam flange width b mm	Beam flange thickness t max. mm	Curve radius min. m	Electric trolley travel speed m/min at 50 Hz	Electric trolley motor kW at 50 Hz
1600 - 5000	A	98 - 180	27	2.0	11 or 11/2.8	0.37 or 0.3/0.09
1600 - 5000	B	180 - 300	27	1.8	11 or 11/2.8	0.37 or 0.3/0.09
7500 - 10000	B	125 - 310	40	1.8	5 or 5/1.25	0.55 or 0.55/0.12

Dimensions model CPE/CPEF

Model	CPE/CPEF 16-8	CPE/CPEF 20-8	CPE/CPEF 25-5	CPE/CPEF 30-5	CPE/CPEF 32-4	CPE/CPEF 40-4	CPE/CPEF 50-2	CPE/CPEF 75-1,6	CPE/CPEF 100-2
A, mm	516	516	516	516	681	681	681	950	1068
A1, mm	286	286	286	286	428	428	428	479	651
A2 (13 m), mm	430	430	430	430	430	430	430	-	-
A2 (21 m), mm	530	530	530	530	530	530	530	530	555
B, mm	35	35	35	35	45	45	45	60	60
C, mm	37	37	37	37	46	46	46	52	52
D, mm	24	24	24	24	30	30	30	40/45	40/45
E, mm	24	24	24	24	24	24	24	-	-
F1, mm	160	160	160	160	160	160	160	160	160
F2, mm	178	178	178	178	178	178	178	178	178
G, mm	220	220	220	220	220	220	220	220	-
G1, mm	180	180	180	180	140	140	140	268	315
G2 (13 m), mm	257	257	257	257	218	218	218	-	-
G2 (21 m), mm	277	277	277	277	238	238	238	345	408
H1, mm	110	110	110	110	110	110	110	110	135
H2, mm	135	135	135	135	135	135	135	307	256
K1, mm	100	100	100	100	100	100	100	92	92
K2, mm	51	51	51	51	51	51	51	62	62
M, mm	50	50	50	50	10	10	10	138	-
N, mm	84	84	84	84	124	124	124	136	390
Q1, mm	280	280	280	280	280	280	280	280	280
Q2 (CPE), mm	362	362	362	362	362	362	362	362	362
Q2 (CPEF), mm	417	417	417	417	417	417	417	417	417

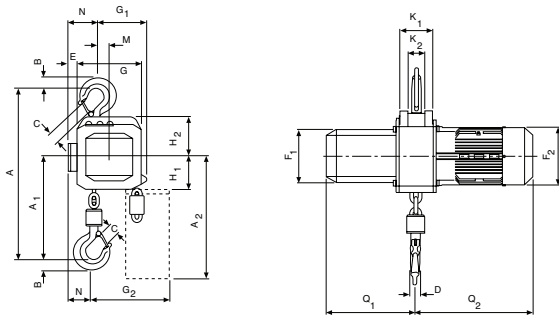

Model CPE/CPEF with suspension hook, 1600 - 3000 kg, single fall

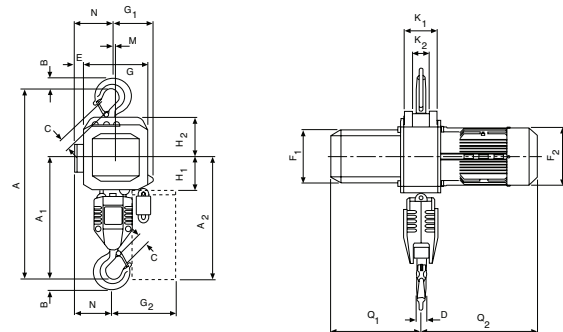

Model CPE/CPEF with suspension hook, 3200 - 5000 kg, double fall

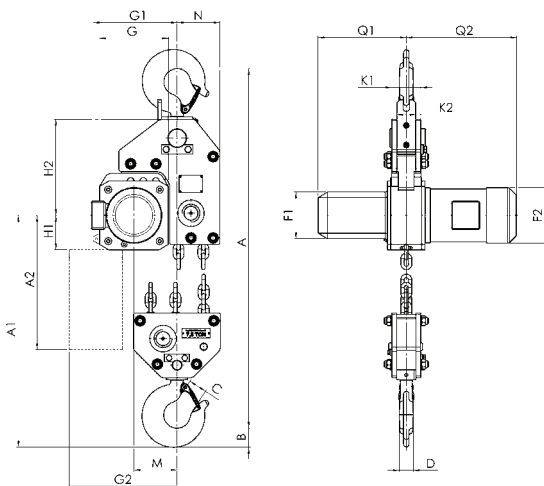

Model CPE/CPEF 75-1,6 with suspension hook, 7500 kg

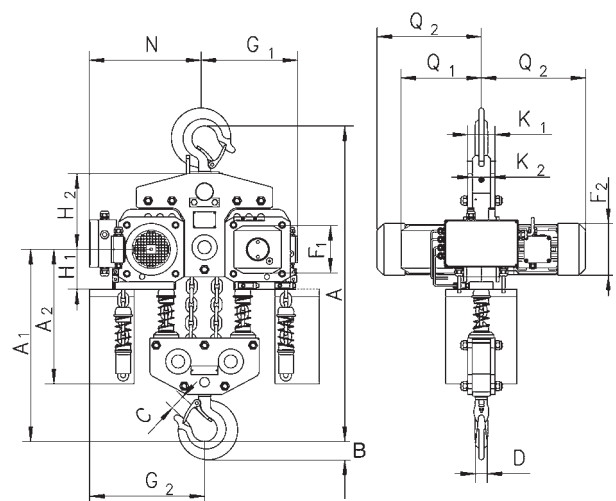

Model CPE/CPEF 100-2 with suspension hook, 10000 kg

Dimensions model CPE/CPEF

Model	CPE/CPEF 16-8	CPE/CPEF 20-8	CPE/CPEF 25-5	CPE/CPEF 30-5	CPE/CPEF 32-4	CPE/CPEF 40-4	CPE/CPEF 50-2	CPE/CPEF 75-1,6	CPE/CPEF 100-2
A3, mm	121	121	121	121	121	121	121	-	110
A4, mm	465	465	465	465	615	615	615	855	965
A5, mm	298	298	298	298	298	298	298	477	450
A6, mm	178	178	178	178	178	178	178	-	170
b, mm	A = 98 - 180/ B = 180 - 300	A = 98 - 180/ B = 180 - 300	A = 98 - 180/ B = 180 - 300	A = 98 - 180/ B = 180 - 300	A = 98 - 180/ B = 180 - 300	A = 98 - 180/ B = 180 - 300	A = 98 - 180/ B = 180 - 300	125 - 310	125 - 310
F, mm	150	150	150	150	150	150	150	113	113
l, mm	142.5	142.5	142.5	142.5	142.5	142.5	142.5	170	170
L1, mm	209	209	209	209	209	209	209	200	200
L2, mm	262.5	262.5	262.5	262.5	262.5	262.5	262.5	215	215
L3 (VTE), mm	292	292	292	292	292	292	292	-	335
L3 (VTEF), mm	296	296	296	296	296	296	296	-	335
L4, mm	213	213	213	213	253	253	253	215	390
L5, mm	312	312	312	312	272	272	272	215	215
L6 (VTE), mm	342	342	342	342	342	342	342	-	-
L6 (VTEF), mm	346	346	346	346	306	306	306	-	-
O, mm	125	125	125	125	125	125	125	150	150
P (VTE), mm	197	197	197	197	197	197	197	-	273
P (VTEF), mm	205	205	205	205	205	205	205	-	280
P1, mm	229	229	229	229	229	229	229	-	110
S, mm	b + 70	b + 70	b + 70	b + 70	b + 70	b + 70	b + 70	b + 98	b + 98
T, mm	94	94	94	94	94	94	94	-	94
tmax., mm	27	27	27	27	27	27	27	40	40

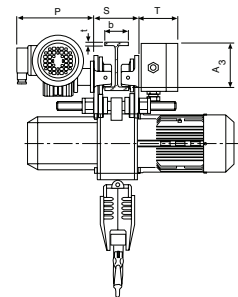
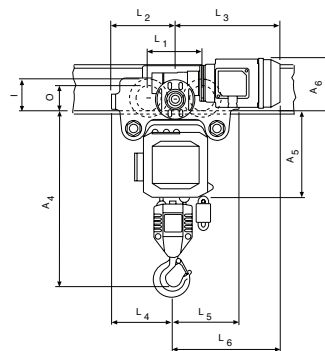
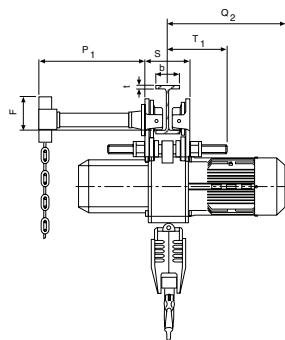
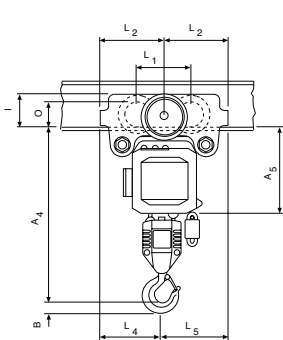

Model CPE/CPEF with integrated manual push or geared trolley

Model CPE/CPEF with integrated electric trolley

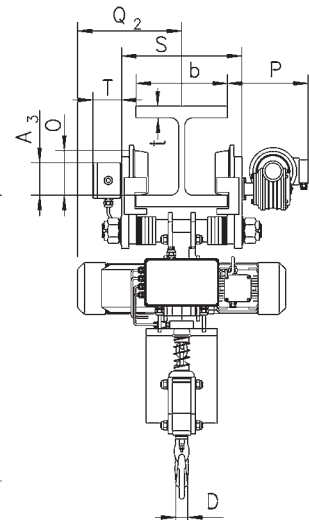
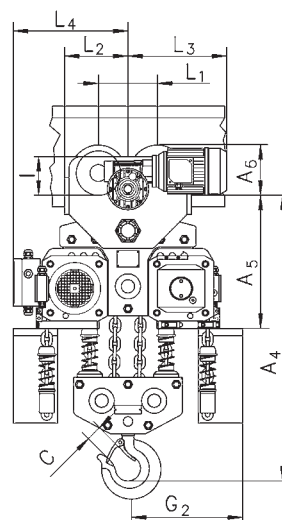
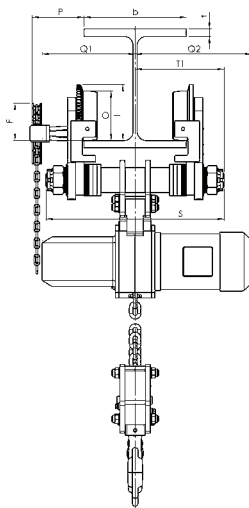
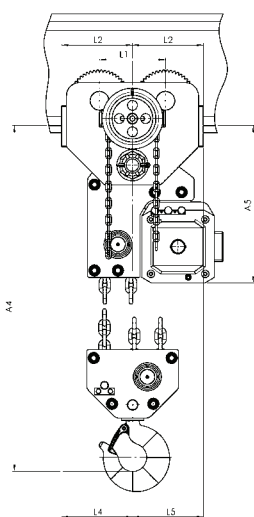

Model CPE/CPEF with integrated geared or electric trolley, 7500 kg

Model CPE/CPEF with integrated electric trolley, 10000 kg